



BID NUMBER: HDA/HO/2024/056

THE APPOINTMENT OF A SERVICE PROVIDER FOR THE SUPPLY AND MAINTENANCE OF 60 NON-FLUSH PORTABLE CHEMICAL TOILETS FOR THE TEMPORARY RELOCATION AREA (TRA) WELMOED TRANSITIONAL RELOCATION AREA FOR A PERIOD OF 24 MONTHS.

CLOSING DATE	02 APRIL 2025	
CLOSING TIME	11:00	
Compulsory briefing session	NO	
BID DOCUMENTS DELIVERY ADDRESS	THE HOUSING DEVELOPMENT AGENCY Reception Area 04 Kikuyu Road Sunninghill 2157	
BIDDER NAME		
BID RETURN ADDRESS	THE HOUSING DEVELOPMENT AGENCY 04 Kikuyu Road Sunninghill 2157	



Disclaimer

This document is provided solely for the purpose set out in this RFP and is not intended to form any part or basis of any investment decision by Bidders. The recipient should not consider the document as an investment recommendation by the HDA or any of its advisers.

Each person to whom this document (and other later documents) is made available must make his own independent assessment of the Project after making such investigation and taking such professional advice as he/she or it deems necessary. Neither the receipt of this document or any related document by any person, nor any information contained in the documents or distributed with them or previously or subsequently communicated to any Bidder or its advisers, is to be taken as constituting the giving of an investment advice by the Housing Development Agency or its advisers.

Whilst reasonable care has been taken in preparing this RFP and other documents, they do not purport to be comprehensive or true and correct. Neither the HDA nor any of its advisers accept any liability or responsibility for the adequacy, accuracy or completeness of any of the information or opinions stated in any document.

They acquaint themselves with this RFP and take note that no representation or warranty, express or implied, is or will be given by the HDA, or any of its officers, employees, servants, agents or advisers with respect to the information or opinions contained in any document or on which any document is based. Any liability in respect of such representations or warranties, howsoever arising is hereby expressly disclaimed.

If any recipient, or its employees, advisers or agents make or offers to make any gift to any of the employees of the HDA or consultant to the HDA on the RFP either directly or through an intermediary then such recipient, Bidder will be disqualified forthwith from participating in the RFP.

Each recipient of this RFP agrees to keep confidential any information of a confidential nature which may be contained in the information provided (the "Confidential Information Provided"). The Confidential Information provided may be made available to Bidder's subcontractors, employees and professional advisers who are directly involved in the appraisal of such information (who must be made aware of the obligation of confidentiality) but shall not, either in the whole or in part, be copied, reproduced, distributed or otherwise made available to any other party in any circumstances without the prior written consent of the HDA, nor may it be used for any other purpose than that for which it is intended.

These requirements do not apply to any information, which is or becomes publicly available or is shown to have been made available (otherwise than through a breach of a confidentiality obligation). Bidders, Key



Contractors and their constituent members, agents and advisers, may be required to sign confidentiality contracts/undertakings (in such form as the HDA may require from time to time).

All Confidential Information Provided (including all copies thereof) remains the property of the HDA and must be delivered to the HDA on demand. Further, by receiving this RFP each Bidder and each of its members agrees to maintain its submission in Bid to this RFP confidential from third parties other than the HDA and its officials, officers and advisers who are required to review the same for the purpose of procurement of the RFP.

Any recipient residing outside the Republic of South Africa is urged to familiarise themselves with and to observe any regulatory requirements relevant to the proposed transaction (whether these derive from a regulatory authority within or outside the Republic of South Africa).

Any requirement set out in this RFP regarding the content of a response to the RFP is stipulated for the sole benefit of the HDA, and serves as expressly stated to the contrary, may be waived at its discretion at any stage in the procurement process.

The HDA is not committed to any course of action as a result of its issuance of this RFP and/or its receipt of a Proposal in response to it. Please note that the HDA reserves the right to:

- Modify the RFP's goods / service(s) / works and request Bidders to re-bid on any changes;
- Withdraw, amend the RFP at any time without prior notice and liability to compensate or reimburse any bidder;
- Reject any Proposal which does not conform to instructions and specifications which are detailed herein
- Disqualify Proposals submitted after the stated submission deadline;
- Call a bidder to provide additional documents which the HDA may require which have not been submitted to The HDA.
- Not necessarily accept the lowest priced Proposal or alternative bid;
- Not accept any response to the RFP or appoint a final bidder;
- Reject all proposals if so decides;
- Withdraw the RFP on good cause shown;
- Award a contract in connection with this Proposal at any time after the RFP's closing date;
- Award a contract for only a portion of the proposed goods/ service/s/ works which are reflected in the scope of this RFP;



- The HDA may split the award of the contract between more than one Service Provider should it be more advantageous in terms of, amongst others, cost or development considerations;
- Make no award at all;
- Validate any information submitted by Bidders in response to this bid. This would include, but is not limited to, requesting the Bidders to provide supporting evidence. By submitting a bid, Bidders hereby irrevocably grant the necessary consent to the HDA to do so;
- Request annual financial statements prepared and signed off by a professional accountant or other documentation for the purposes of a due diligence exercise; and/or
- Not accept any changes or purported changes by the Bidder to the bid rates after the closing date and/or after the award of the business, unless the contract specifically provided for it.

All costs and expenses incurred by Bidders in submitting responses to this RFP shall be borne by the Bidders and the HDA shall not be liable for any costs or expenses whatsoever or any claim for reimbursement of such costs or expenses.

Should a contract be awarded on the strength of information furnished by the Bidder, which after conclusion of the contract, is proved to have been incorrect, the HDA reserves the right to cancel the contract and/or place the Bidder on the HDA's list of Restricted Suppliers.

The HDA reserves the right to negotiate market-related price with the bidder scoring the highest points or cancel the bid; if the bidder does not agree to a market related price, negotiate a market related price with the bidder scoring the second highest points or cancel the bid; if the bidder scoring the second highest points does not agree to a market related price, negotiate a market related price with the bidder scoring the third highest points or cancel the bid. If the market related price is not agreed as envisaged in this paragraph, the HDA will cancel the bid.

The HDA reserves the right to negotiations Best and Final Offer (BAFO) with selected Bidders where none of the Proposals meet RFP requirement, are affordable and demonstrate value for money and there is no clear preferred response to the RFP

Should the preferred bidder fail to sign or commence with the contract within a reasonable period after being requested to do so, the HDA reserves the right to award the business to the next ranked bidder, provided that he/she is still prepared to provide the required goods at the quoted price. Under such circumstances, the validity of the bids of the next ranked bidder(s) will be deemed to remain valid, irrespective of whether the next ranked bidder(s) were issued with a Letter of Regret. Bidders may therefore be requested to advise



whether they would still be prepared to provide the required goods at their quoted price, even after they have been issued with a Letter of Regret.

The HDA will not reimburse any Bidder for any preparatory costs or other work performed in connection with its Proposal, whether or not the Bidder is awarded a contract.

SCHEDULE OF BID DOCUMENTS

SECTION NO	PAGE
SECTION 1 : NOTICE TO BIDDERS	
1 <u>INVITATION TO BID</u>	13
2 <u>PROPOSAL SUBMISSION</u>	14
3 <u>DELIVERY INSTRUCTIONS FOR RFP</u>	14
4 <u>SPECIFIC GOALS</u>	14
5 <u>COMMUNICATION</u>	15
7 <u>CONFIDENTIALITY</u>	15
8 <u>INSTRUCTIONS FOR COMPLETING THE RFP</u>	16
9 <u>LEGAL COMPLIANCE</u>	18
10 <u>NATIONAL TREASURY'S CENTRAL SUPPLIER DATABASE</u>	18
11 <u>TAX COMPLIANCE</u>	19
12 <u>PROTECTION OF PERSONAL DATA</u>	19
<u>SECTION 2 : BACKGROUND, OVERVIEW AND SCOPE OF REQUIREMENTS</u>	20
1 <u>INTRODUCTION AND BACKGROUND</u>	20
2 <u>OVERVIEW</u>	22
3 <u>KEY OBJECTIVES OF THE RFP</u>	23
4 <u>SCOPE OF WORK</u>	23
5 <u>EVALUATION METHODOLOGY</u>	23
6 <u>VALIDITY PERIOD</u>	29
7 <u>THE NATIONAL INDUSTRIAL PARTICIPATION PROGRAMME</u>	29
8 <u>POST TENDER NEGOTIATION (IF APPLICABLE)</u>	29
9 <u>BEST AND FINAL OFFER</u>	29
10 <u>FINAL CONTRACT AWARD</u>	29
11 <u>FAIRNESS AND TRANSPARENCY</u>	30



<u>SECTION 3 : PRICING AND DELIVERY SCHEDULE</u>	31
<u>1 PRICING</u>	32
<u>2 DISCLOSURE OF PRICES QUOTED</u>	32
<u>3 OWNERSHIP OF DESIGN</u>	32
<u>4 SERVICE LEVELS</u>	32
<u>5 TOTAL COST OF OWNERSHIP</u>	32
<u>6 FINANCIAL STABILITY</u>	33
<u>7 VALIDITY OF RETURNABLE DOCUMENTS</u>	34
<u>8 CERTIFICATE OF ACQUAINTANCE WITH RFP TERMS AND CONDITIONS</u>	35
<u>9 GENERAL CONDITIONS</u>	36
<u>10 CONDITIONS OF TENDER</u>	42



LIST OF APPENDICES

INVITATION TO BID	SBD 1
DECLARATION OF INTERESTS	SBD 4
PREFERENCE POINTS CLAIM FORM	SBD 6.1
GCC	



1 LIST OF ANNEXURES

Detailed Scope of Work (Project Specification)

Annexure 1

Pricing Schedule

Annexure 2



2 ACRONYMS

BBBEE	Broad Based-Black Economic Empowerment
CIDB	Construction Industry Development Board
DTiC	The Department of Trade and Industry and Competition
PPPFA	Preferential Procurement Policy Framework Act 5 of 2000 (as amended from time to time)
PFMA	Public Finance Management Act No.1 of 1999 (as amended from time to time)
The HDA	The Housing Development Agency
RFP	Request for Proposal
SANAS	South African National Accreditation System

3 INTERPRETATION

In this RFP, unless inconsistent with or otherwise indicated by the context –

- 3.1** headings have been inserted for convenience only and should not be taken into account in interpreting the RFP;
- 3.2** any reference to one gender shall include the other gender;
- 3.3** words in the singular shall include the plural and vice versa;
- 3.4** any reference to natural persons shall include legal persons and vice versa;
- 3.5** words defined in a specific clause have the same meaning in all other clauses of the RFP, unless the contrary is specifically indicated;
- 3.6** any reference to the RFP, schedule or appendix, shall be construed as including a reference to any RFP, schedule or appendix amending or substituting that RFP, schedule or appendix;
- 3.7** the schedules, appendices and Briefing Notes issued pursuant to this RFP, form an indivisible part of the RFP and together with further clarifying and amending information provided by the HDA, constitute the body of RFP documentation which must be complied with by Bidders;
- 3.8** in the event of any inconsistency between this RFP or other earlier information published with regard to the Project, the information in this RFP shall prevail; and
- 3.9** this RFP shall be governed by and applied in accordance with South African law.

4 DEFINITIONS

In this RFP and in any other project documents (as defined below) which so provides, the following words and expressions shall have the meaning assigned to them below and cognate expressions shall have a corresponding meaning, unless inconsistent with the context:

- 4.1 “Accounting Authority” means the Board of the HDA;
- 4.2 “Contract” means the Contract to be entered between the HDA and the successful Bidder for the provision of the *services* procured in this RFP.
- 4.3 “Bid” means the Bid to the RFP submitted by Bidders;
- 4.4 “Bidders Briefing Session” means the compulsory or non-compulsory briefing session to be held at the offices of the HDA or at a venue that will be arranged by the HDA, in order to brief the Bidders about this tender;
- 4.5 “Black Enterprise” means an enterprise that is at least 51% beneficially owned by Black People and in which Black People have substantial Management Control. Such beneficial ownership may be held directly or through other Black Enterprises;
- 4.6 “Black Equity” means the voting equity held by Black People from time to time;
- 4.7 “Black People” means African, Coloured, and Indian South African citizens, and “Black Person” means any such citizen ;
- 4.8 “Black Woman” means African, Coloured, and Indian South Africa Female citizen;
- 4.9 “Briefing Note” means any correspondence to Bidders issued by the HDA;
- 4.10 “Business Day” means any day except a Saturday, Sunday or public holiday in South Africa;
- 4.11 “Bidders” means individuals, organisations or consortia that have been submitted responses to the RFP in respect of the tender;
- 4.12 “Consortium” means any group of persons or firms jointly submitting a Bid as Bid to this RFP and “Consortia” means more than one Consortium;
- 4.13 “Contractor” the successful Bidders who has signed a Contract with the HDA in terms of this RFP.
- 4.14 “Closing Date” means the closing date for submission of bids
- 4.15 “Project” means this project for **“The Appointment of a Service Provider for the Supply and Maintenance of 60 Non-Flush Portable Chemical Toilets for The Temporary Relocation Area (TRA) Welmoed Transitional Relocation area for a period of 24 Months”**.
- 4.16 “RFP” means the Request for Proposals issued by the HDA for this tender; and
- 4.17 “Scope of Work” means the scope of work for this project as detailed out in the RFP technical specifications.

SECTION 1

NOTICE TO BIDDERS

1 INVITATION TO BID

You are hereby invited to submit a bid to meet the requirements of the Housing Development Agency. Responses to this RFP [hereinafter referred to as a **Bid** or a **Proposal**] are requested from persons, companies, close corporations, or enterprises [hereinafter referred to as an **entity, Bidder**].

BID DESCRIPTION	The Appointment of a Service Provider for the Supply and Maintenance of 60 Non-Flush Portable Chemical Toilets for The Temporary Relocation Area (TRA) Welmoed Transitional Relocation area for a period of 24 Months.
BID ADVERT	This RFP may be downloaded directly from National Treasury's e-Tender Publication Portal at www.etenders.gov.za or the HDA website at www.thehda.co.za/procurement/currenttenders free of charge. With effect from 11 March 2025
ISSUE DATE	11 March 2025
COMPULSORY BRIEFING SESSION	No
CLOSING DATE	11H00am on 02 April 2025 Bidders must ensure that bids are delivered timeously to the correct address. As a general rule, if a bid is late or delivered to the incorrect address, it will not be accepted for consideration.
VALIDITY PERIOD	120 Business Days from Closing Date Bidders are to note that they may be requested to extend the validity period of their bid, at the same terms and conditions, if the internal evaluation process has not been finalised within the validity period.



CLOSING DATE FOR QUESTIONS	25 March 2025
CLOSING DATE FOR RESPONSES	28 March 2025
CONTACT DETAILS	tender3@thehda.co.za

Any additional information or clarification will be emailed to all Bidders, if necessary.

2. PROPOSAL SUBMISSION OF RFP RESPONSE

Proposal Responses must be submitted to the HDA in a sealed envelope/package addressed as follows:

Attention: SCM Office

RFP No:	HDA/HO/2024/056
Description of Bid	The Appointment of a Service Provider for the Supply and Maintenance of 60 Non-Flush Portable Chemical Toilets for The Temporary Relocation Area (TRA) Welmoed Transitional Relocation area for a period of 24 Months.
Closing date and time:	02 April 2025 at 11h00
Closing address	Housing Development Agency Head Office, 4 Kikuyu Road, Sunninghill

3. DELIVERY INSTRUCTION FOR RFP

Delivery of Bid

The Bid envelopes/packages must be deposited in the HDA tender box which is located at the HDA and must be addressed as follows:

The Housing Development Agency
4 Kikuyu Road
Sunninghill

4. SPECIFIC GOALS

As explained in more detail in the attached SBD 6.1 (Specific Goals Preference Points Claim Form) and as prescribed in terms of the Preferential Procurement Policy Framework Act (PPPFA), Act 5 of



2000 and its Regulations, Bidders are to note that the HDA will award “Specific Goals points” to companies who provide valid proof of their status as requested in the bid document.

4.2. SPECIFIC GOALS FOR JOINT VENTURES OR CONSORTIUMS

Bidders who would wish to respond to this RFP as a Joint Venture [JV] or consortium, must state their intention to do so in their RFP submission. Such Bidders must also submit a signed JV or consortium agreement between the parties clearly stating the percentage [%] split of business and the associated responsibilities of each party.

Bidders are to note the requirements for specific goals compliance of JVs or consortiums as required by SBD 6.1 [the specific goals Preference Point Claim Form] and submit it together with proof of their consolidated specific goals as stipulated in the Claim Form in order to obtain preference points.

5. COMMUNICATION

For specific queries relating to this RFP during the RFP process, bidders are required to adhere strictly to the communication structure requirements. Queries should be submitted to Tender3@thehda.co.za on or before **16h30pm on 28 March 2025**

5.2. In the interest of fairness and transparency the HDA’s response to such a query will be made available to the Bidders on the National Treasury E-Tender portal and the HDA’s Website.

5.3. After the closing date of the RFP, a Bidder may only communicate in writing with the SCM Official, at Tender3@thehda.co.za on any matter relating to its RFP Proposal.

5.4. Bidders are to note that changes to its submission will not be considered after the closing date.

5.5. Bidders are warned that a response will be liable for disqualification should any attempt be made by a Bidder either directly or indirectly to canvass any officer(s) or employee of the HDA in respect of this RFP between the closing date and the date of the award of the business. Furthermore, Bidders found to be in collusion with one another will automatically be disqualified and restricted from doing business with the HDA in future.

6. CONFIDENTIALITY

6.2. The HDA shall ensure all information related to this RFP is to be treated with strict confidence. In this regard Bidder / Bidders are required to certify that they have acquainted themselves with the Non-



Disclosure Agreement. All information related to a subsequent contract, both during and after completion thereof, will be treated with strict confidence. Should the need however arise to divulge any information gleaned from provision of the Services , which is either directly or indirectly related to the HDA's business, written approval to divulge such information must be obtained from the HDA.

6.3. Bidders must clearly indicate whether any information submitted or requested from the HDA is confidential or should be treated confidentially by the HDA. In the absence of any such clear indication in writing, the HDA shall deem the response to the RFP to have waived any right to confidentiality and treat such information as public in nature.

7. INSTRUCTIONS FOR COMPLETING THE RFP

7.2. All responses to the RFP must be submitted in two sealed envelopes/boxes; the first envelop/box shall have the technical, compliance and specific goals response and the second envelop/box shall only have the financial response. Bidders must ensure that they do not indicate any financial information in the first envelop/box. the HDA may disqualify Bidders who fail to adhere to this requirement.

7.3. Bidders are required to package their response/Bid as follows to avoid disqualification:

Volume 1 (Envelop 1/Package 1)

- **Part A:** Compliance Response
- **Part B:** Technical or Functional Response (response to scope of work)

Volume 2 (Envelop 2/ Package 2)

- **Part C:** Financial Proposal and specific goals (SBD6.1)

Volume 2 Has to be submitted in a separate sealed envelope. Bidders must make their pricing offer in envelop 2/package 2, **NO PRICING AND PRICING RELATED INFORMATION SHOULD BE INCLUDED IN THE VOLUME 1 ENVELOP 1.**

7.4. Bidders must submit 1 original response, and electronic version which must be contained in USB clearly marked in the Bidders name.

7.5. Bidders must ensure that their response to the RFP is in accordance with the structure of this document.

7.6. Where Bidders are required to sign forms they are required to do so using a black ink pen.



- 7.7. Any documents forming part of the original responses to RFP but which are not original in nature, must be certified as a true copy by a Commissioner of Oaths.
- 7.8. Each response to RFP must be in English and submitted in A4 format, except other graphic illustrations, which may not exceed A3 format, unless the contrary is specifically allowed for in this RFP. Responses to RFP must be neatly and functionally bound, preferably according to their different sections.
- 7.9. The original responses to RFP must be signed by a person duly authorized by each consortium member and Subcontractor to sign on their behalf, which authorization must form part of the responses to RFP as proof of authorization. By signing the responses to RFP the signatory warrants that all information supplied by it in its responses to RFP is true and correct and that the responses to RFP and each party whom the responses to RFP signatory represents, considers themselves subject to and bound by the terms and conditions of this RFP.
- 7.10. The responses to RFP formulation must be clear and concise and follow a clear methodology which responses to RFP must explain upfront in a concise Executive Summary and follow throughout the responses to RFP.
- 7.11. Responses to RFP must provide sufficient information and detail in order to enable the HDA to evaluate the responses to RFP, but should not provide unnecessary detail which does not add value and detracts from the ability of the HDA to effectively evaluate and understand the responses to RFP. The use of numbered headings, bullet points, sections, appendices and schedules are encouraged.
- 7.12. Information submitted as part of a responses to RFP must as far as possible, be ordered according to the order of the required information requested by the HDA. All pages must be consecutively numbered.
- 7.13. Responses to RFP must ensure that each requirement contained in the RFP is succinctly addressed. Responses to RFP should as far as possible use the terms and definitions applied in this RFP and should clearly indicate its interpretation of any differing terminology applied.
- 7.14. Response to RFP documents are to be submitted to the address specified in paragraph 3 above, and Bidders must ensure that the original and copies (where applicable) are identical in all respects as the HDA will not accept any liability for having disqualified a bidder for failing to provide a mandatory returnable document.
- 7.15.** Unless otherwise expressly stated, all Proposals furnished pursuant to this RFP shall be deemed to be offers. Any exceptions to this statement must be clearly and specifically indicated.



8. LEGAL COMPLIANCE

Bidders must ensure that they comply with all the requirements of the RFP and if Bidders fail to submit any of the required documents, such Bids shall, at the sole discretion of the HDA, be disqualified the Bidder. The HDA reserves the right to call a Bidder to provide additional documents which the HDA may require from a Bidder which have not been submitted to the HDA.

Bidders must ensure that they comply with all the requirements of the RFP and if Bidders fail to submit any of the required documents, such Bids shall, at the sole discretion of the HDA, be disqualified.

The successful Bidder [hereinafter referred to as the **Service Provider**] shall be in full and complete compliance with any and all applicable laws and regulations.

9. NATIONAL TREASURY'S CENTRAL SUPPLIER DATABASE

Bidders are required to self-register on National Treasury's Central Supplier Database (CSD) which has been established to centrally administer supplier information for all organs of state and facilitate the verification of certain key supplier information. Only foreign suppliers with no local registered entity need not register on the CSD. The CSD can be accessed at <https://secure.csd.gov.za>. Bidders are required to provide the following to the HDA in order to enable it to verify information on the CSD:

Supplier Number: _____ **Unique registration reference number:** _____

10. TAX COMPLIANCE

Bidders must be compliant when submitting a proposal to the HDA and remain compliant for the entire contract term with all applicable tax legislation, including but not limited to the Income Tax Act, 1962 (Act No. 58 of 1962) and Value Added Tax Act, 1991 (Act No. 89 of 1991).

It is a condition of this RFP that the tax matters of the successful bidder be in order

The Tax Compliance status requirements are also applicable to foreign Bidders/ individuals who wish to submit bids.

Bidders are required to be registered on the CSD as indicated in paragraph 9 and the National Treasury shall verify the Bidder's tax compliance status through the CSD.

Where Consortia / Joint Ventures / Sub-contractors are involved, each party must be registered on the CSD and their tax compliance status will be verified through the CSD.



For this purpose, the attached SBD 1 must be completed and submitted as an essential returnable document by the closing date and time of the bid.

New Tax Compliance Status (TCS) System

SARS has implemented a new Tax Compliance Status (TCS) system in terms of which a taxpayer is now able to authorise any 3rd party to verify its compliance status in one of two ways: either through the use of an electronic access PIN, or through the use of a Tax Clearance Certificate obtained from the new TCS system.

Bidders are required to provide the following to the HDA in order to enable it to verify their tax compliance status:

Tax Compliance Status (TCS) Pin: _____

11. PROTECTION OF PERSONAL DATA

In responding to this bid, the HDA acknowledges that it may obtain and have access to personal data of the Bidders. the HDA agrees that it shall only process the information disclosed by Bidders in their response to this bid for the purpose of evaluating and subsequent award of business and in accordance with any applicable law. Furthermore, the HDA will not otherwise modify, amend or alter any personal data submitted by Bidders or disclose or permit the disclosure of any personal data to any Third Party without the prior written consent from the Bidders. Similarly, the HDA requires Bidders to process any personal information disclosed by the HDA in the bidding process in the same manner.

SECTION 2

BACKGROUND OVERVIEW AND SCOPE REQUIREMENTS

Introduction

The Housing Development Agency (HDA) is a national public development agency that promotes sustainable communities by making well-located and appropriately planned land and buildings available for the development of human settlements. As its primary activity, the HDA assembles state, private and communal land and buildings and releases it for development. In addition, the HDA provides project delivery support services to organs of state at local, provincial and national level.

Background of Welmoed Estate Development

- Welmoed Estate, previously known as “Penhill Greenfields Development Project” comprising approximately 192ha, is owned by the Western Cape Government Department of Infrastructure: Human Settlements Branch and was identified as a site that can accommodate many people from areas that are in much need of housing.
- The project is envisaged as a catalytic development project part of the southern corridor which aims to expand housing delivery for the Penhill Project as well as for those currently living and working in the area and who are on the housing waiting list for a subsidised house.
- Welmoed Estate is being developed in phases and will take place over several years. The first phase of development is the Southern Precinct, and it will provide approximately 3900 housing opportunities. The project will include predominantly subsidised housing, along with associated community facilities and business opportunities.
- The Western Cape Department of Infrastructure: Human Settlements Branch has appointed a contractor for the installation of services and construction of top structures.
- The overall Welmoed Estate site is characterised by scattered human occupation in the form of small-scale farming and associated dwellings. While large areas remain vacant, the site is mostly degraded and of low agricultural value.

- The HDA will undertake the provision of management of the TRA through an appointed Service Provider to allow for the relocation of persons during the construction phases of the Welmoed Estate Development

Transitional Relocation Area (TRA)

- A suitable TRA was investigated in the Northern Precinct of the site and several factors had to be considered, such as access, availability of services, threats of land invasions, environmental suitability, and mediation with the current occupiers.
- The TRA is in the North-Eastern part of Welmoed Estate, between the Eskom power line servitude and the agricultural area. The appointed service provider will be required to attend to the provision of security, regular and emergency maintenance of the facility and its structures and the overall coordination of the TRA's during the period of the contract.
- The TRA is currently being fully maintained, including roads, fencing and ablutions, among other components, by the contractor responsible for the construction of top structures. It is envisaged that some of the project's beneficiaries will be drawn from the TRA occupiers and the TRA would be decommissioned, and services terminated for infrastructure to be removed as and when it is no longer required to temporarily accommodate people from this community.

The TRA is situated at approximately the following co-ordinates. -33.971568811728794, 18.720161690183087

Figure 1 represented the approximate location of the TRA within the surrounding neighbourhoods.

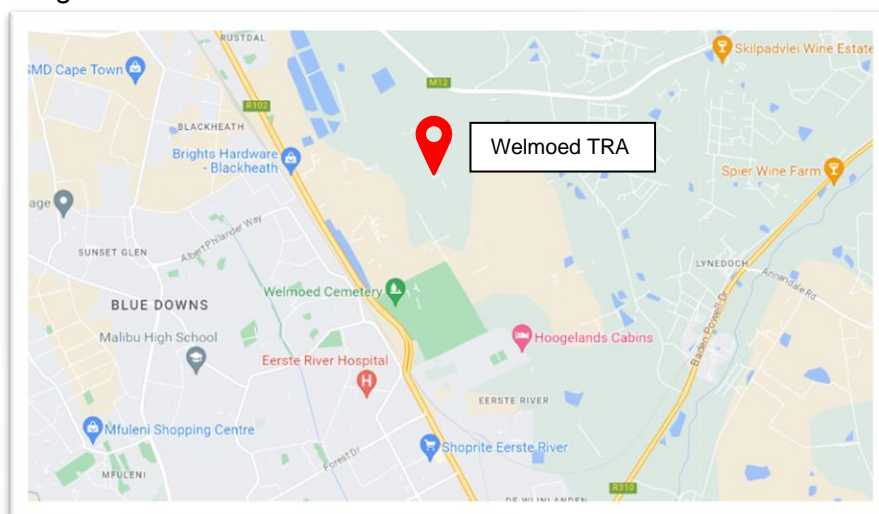

Scope and TRA Layout

A comprehensive feasibility study was conducted, in respect of the three alternatives and the study informed the preferred alternative. In terms of the TRA for Welmoed Estate, the alternative for individual plots was considered appropriate. The TRA measures approximately 2.3ha. The TRA comprises 292 individual units each measuring approximately 24m² in extent. The erven are arranged in rows creating eight (8) residential blocks. An open space area is provided in the centre of the TRA, and a site has been allocated for a creche for the children that will form part of the community. A portion of the site has been dedicated for a Limited Use zone if it may be required to be used by the TRA residents.

The site is bounded by a perimeter road for circulation, and to allow for fire- and emergency vehicle access. A smaller 5m wide lane extends through the site for internal circulation and emergency services, along with narrower 3m wide lanes. Provision is made for six (6) ablution blocks and four (4) refuse skips distributed at regular locations along the perimeter road. Refer to Annexure A1-TRA Services Layout, Annexure A2 – TRA Proposed Layout and Annexure A3 – TRA Unit Layout.

Municipal Engineering Services

Existing Electrical Services: The Development and the TRA is situated within the electricity license supply area and jurisdiction of Eskom. There are existing Eskom services crossing the intended new development, these include the 400kV, 132kV and a 66kV Eskom line.

TRA Civil Engineering Services: The availability of Engineering Services was investigated by the appointed Civil Engineering Consultants SMEC. Water supply is sourced from the existing Kleinvlei reservoir supply pipe. Approval for connection to the supply water pipe has been received from the City of Cape Town. Internal water supply consists of standpipes located throughout the TRA.

Temporary Sewerage Disposal: Temporary sewage disposal is provided in the form of chemical toilets and thus there is no need for Municipal sewer connections. The proposed communal ablution facilities will accommodate chemical toilets and hand wash basins. Ablution facilities are located adjacent to the perimeter road, so that servicing of the chemical toilets can be done efficiently.



Waste Water Disposal: grey water drains into 12 septic tanks, each of the six (6) ablution facilities have 2 x 6000 litre underground tanks. These will need to be emptied out once a week (every seven days). Thus 72 000 litres will need to be disposed of according to municipal by-laws.

Objective of the proposed project

The objective is to provide the occupants of the Welmoed Transitional Residential Area (TRA) with a relatively safe and liveable environment during the development and construction of Welmoed Estate.

Scope Of Work

The following work shall be expected from the contractor: -

Repairs and Maintenance
<ul style="list-style-type: none"> • Renting of 60 non-flush portable chemical toilets and honey sucked 3 x a week.
<ul style="list-style-type: none"> • Daily cleaning and sanitising of 60 non-flush portable chemical toilets (cleaning materials to be provided by the Service Provider).
<ul style="list-style-type: none"> • Daily cleaning, sanitising, and maintenance of 6 ablution blocks. (concrete floor supporting the 60 non-flush portable chemical toilets and 12 concrete wash troughs)
<ul style="list-style-type: none"> • Employ 6 local labourers and 1 supervisor.
<ul style="list-style-type: none"> • Emptying of 12 X 6000 litre wastewater tanks and the appropriate disposal of wastewater, in keeping with the applicable bylaws and environmental standards.
<ul style="list-style-type: none"> • Emptying out of 72 000 litres of grey water weekly from septic tanks and disposing thereof.
<ul style="list-style-type: none"> • Ad-Hoc sewer jet cleaning services <p>This will be done as and when requested by the HDA. In each instance, a request will be issued, thereafter a quote to be submitted in writing to the HDA. The HDA will thereafter provide written approval to proceed with the job.</p>

Duration



The anticipated timeframe for the completion of this project is **24 Months**.

1 EVALUATION METHODOLOGY

The evaluation of Bids will be based on the information contained in Bids received in RFP and, which may be further supplemented by presentations and clarification information provided, if required. All Bids shall be equally evaluated and adjudicated by various committees involved in the evaluation process in accordance with stated Evaluation Criteria. Procurement integrity and fairness, transparency, competitiveness and full accountability will at all times be paramount.

1.1 EVALUATION AND SCORING METHODOLOGY

The evaluation of the Bids by the evaluation committee will be conducted at various stages.

The following stages will be applied in the evaluation:

STAGE	DESCRIPTION
Admin compliance (Stage 1)	The Bid is checked for completeness and whether all required documentation, certificates; verify completeness warranties and other Bid requirements and formalities have been complied with. The Bids are checked to verify that the essential RFP requirements have been met. Incomplete and Non-compliant Bids may be disqualified.
Technical Evaluation (Stage 2)	Detailed analysis of Bids to determine whether the Bidder is capable of delivering the Project in terms of business and technical requirements. The minimum threshold for technical evaluation is [70%], any bidder who fails to meet the minimum requirement will be disqualified and not proceed with the evaluation of Price and Specific goals.
Price and Specific goals (Stage 3)	Evaluate price and Specific Goals on an 80/20 point system
Bidder Verification (Stage 4)	Verification of information supplied by bidders when completing SBD 4
Recommendation	Report formulation and recommendation of Preferred Bidders
Best and Final Offer	The HDA may go into the Best and Final Offer process in the instance where no bid meets the requirements of the RFP and/or the Bids are to close in terms of points awarded.



STAGE	DESCRIPTION
Approval	Approval and notification of the final Bidder.

STAGE 1: COMPLIANCE REQUIREMENTS

Stage 1A Basic Compliance

If you do not submit the following basic compliance documents and should an award be made, these basic compliance documents must be made available within seven (7) days, failing which the award will be recalled.

No.	Description of requirement	
a)	Letter of Good Standing: COID	
b)	CSD Report	
C)	Completion of ALL RFP documentation (includes ALL declarations required)	



STAGE 2: TECHNICAL / FUNCTIONALITY REQUIREMENTS

Interested bidders shall then be evaluated on functionality after meeting all compliance requirements outlined above. The minimum threshold for technical/functionality requirements is 70% as per the standard Evaluation Criteria presented as per the table above. Bidders who score below this minimum requirement shall not be considered for further evaluation in stage 3.

TECHNICAL/FUNCTIONAL EVALUATION CRITERIA

Details of the scoring methodology are outlined below:

CRITERIA	SUB-CRITERIA	WEIGHTING/ POINTS
Company Profile	<p>Company Profile to be submitted (in the case of a Joint Venture, all companies to the Joint Venture Agreement must submit separate profiles and a clear indication of the Lead Company)</p> <ul style="list-style-type: none"> • Profile not related to Supply and Maintenance of Chemical Toilets (0 points). • Profile related to Supply and Maintenance of Chemical Toilets (5 points). • Profile related to Supply and Maintenance of Chemical Toilets at least three government departments , Municipalities or Entities (10 points) 	10
Company's Previous Experience in Supply and Maintenance of Chemical Toilets in the form of letters of appointment.	<p>Service Providers to provide appointment letters : -</p> <ul style="list-style-type: none"> • No experience in facilities management (0 points). 	30

CRITERIA	SUB-CRITERIA	WEIGHTING/ POINTS
	<ul style="list-style-type: none"> • 1 to 2 Appointment letters (Supply and Maintenance of Chemical Toilets) (5 points.) • 1 to 2 Appointment letters (Supply and Maintenance of Chemical Toilets in government facilities) (10 points.) • 3 to 4 Appointment letters (Supply and Maintenance of Chemical Toilets in government facilities) (20 points.) • 5 or more Appointment letters (Supply and Maintenance of Chemical Toilets in government facilities) (30 points.) 	
<p>Approach & Methodology & Workplan</p> <p>(Clear and satisfactory approach Methodology, workplan and allocation of resources and tasks to be submitted.)</p>	<p>A written work plan is required</p> <ul style="list-style-type: none"> ○ No Methodology Submitted (0 Point) ○ Basic Methodology submitted = (10 Points) ○ Detailed methodology submitted = (30 Points) covering aspects of <ul style="list-style-type: none"> ○ Supply and Maintenance of Chemical Toilets ○ Risk and legal compliance ○ Occupant management ○ Reports 	<p>30</p>



CRITERIA	SUB-CRITERIA	WEIGHTING/ POINTS
<p>Management Team</p> <p>Nominated management team indicating relevant experience on similar projects</p> <p>(Comprehensive CV outlining Nominated persons relevant experience to be submitted with traceable references.)</p>	<p>A two-person management team comprising of the following personnel: -</p> <p>Contractor Site Supervisor</p> <ul style="list-style-type: none"> • No experience (0 points) • 1 to 2 years experience (5 points) • More than 2 Years experience (15 points) <p>Lead Contract Supervisor</p> <ul style="list-style-type: none"> • No experience (0 points) • 1 to 2 years experience (5 points) • More than 2 Years experience (15 points) 	<p>30</p>
TOTAL		100

STAGE 3: PRICING AND SPECIFIC GOALS

The following criteria will be used for points allocation for price and Specific Goals compliance on a 80/20 point system:

Price and Specific Goals

CRITERIA	WEIGHTING/ POINTS
Price	80
Specific goal	20
Total	100

Price



$$P_s = 80 \left(1 - \frac{P_t - P_{min}}{P_{min}} \right)$$

Where

P_S = Points scored for price of tender under consideration

P_t = Rand value of offer tender consideration

P_{min} = Rand value of lowest acceptable tender

Specific Goals Evaluation:

A bidder must submit proof or documentation to claim points for specific goals. A bidder failing to submit proof or documentation to claim points for specific goals will be interpreted to mean that preference points for specific goals are not claimed. The bidder may not be disqualified but will score 0 points out of 20 for specific goals.

Specific goals for the tender and points claimed are indicated per the table below.

(Note to organs of state: 80/20 preference point system is applicable, corresponding points must also be indicated as such.)

The Specific Goals allocated points in terms of this tender	Number of Points	Proof / Documentation required to Claim Points for Specific Goals
<i>Black Women Owned (Maximum points = 5 points)</i>		
75% - 100%	5	CSD and Sworn Affidavit
51% - 74.99 -	3	CSD and Sworn Affidavit
Below 51%	1	CSD and Sworn Affidavit
<i>Historically Disadvantaged South Africans* (maximum Points = 15)</i>		
<i>Youth (Maximum points 5)</i>	5	CSD
<i>HDSA</i>	3	CSD and Sworn Affidavit
<i>Disabled People</i>	5	CSD and Sworn Affidavit
<i>Military Veterans</i>	2	CSD and Sworn Affidavit

***Historically disadvantaged South Africans refers to any person, category of persons, or communities disadvantaged by unfair discrimination before the constitution of the Republic of SA, 1993 (ACT No. 2000 of 1993 come into operations.**

2 VALIDITY PERIOD



This RFP shall be valid for *[120 Business days]* calculated from Bid closing date.

3 THE NATIONAL INDUSTRIAL PARTICIPATION PROGRAMME

3.1 National Industrial Participation Programme (NIPP) requirements:

The National Industrial Participation (NIP) Programme, which is applicable to all government procurement contracts that have an imported content, became effective on the 1 September 1996. The NIP policy and guidelines were fully endorsed by Cabinet on 30 April 1997. In terms of the Cabinet decision, all state and parastatal purchases / lease contracts (for goods, works and services) entered into after this date, are subject to the NIP requirements. NIP is obligatory and therefore must be complied with. The Industrial Participation Secretariat (IPS) of the Department of Trade and Industry (DTI) is charged with the responsibility of administering the programme.

Bidders are therefore required to complete SBD 5 to give effect to the above.

4 POST TENDER NEGOTIATION (IF APPLICABLE)

The- HDA reserves the right to conduct post tender negotiations with a shortlist of Bidder(s). The shortlist could comprise of one or more Bidders. Should the HDA conduct post tender negotiations, Bidders will be requested to provide their best and final offers to the HDA based on such negotiations. A final evaluation will be conducted in terms of 80/20.

5 BEST AND FINAL OFFER

The HDA reserves the right to embark on the Best and Final Offer (BAFO) Process where:

- a) None of the proposals meet the RFP requirements;
- b) None of the responses to RFP are affordable and demonstrate value for money; and

Upon the decision by the HDA to embark on a BAFO process it shall notify the response to RFP.

6 FINAL CONTRACT AWARD

The HDA may negotiate the final terms and conditions of the contract with the successful Bidder(s).
Bidder



7 FAIRNESS AND TRANSPARENCY

The HDA views fairness and transparency during the RFP Process as an absolute on which the HDA will not compromise. The HDA will ensure that all members of evaluation committees declare any conflicting or undue interest in the process and provide confidentiality undertakings to the HDA.

The evaluation process will be tightly monitored and controlled by the HDA to assure integrity and transparency throughout, with all processes and decisions taken being approved and auditable.

SECTION 3

PRICING AND DELIVERY SCHEDULE

Bidders are required to complete the Pricing Schedule as per **Annexure: 2 (Volume 2 /Envelop 2)**

1 PRICING

- 1.1. Prices must be quoted in South African Rand, inclusive of VAT.
- 1.2. Price offer is firm and clearly indicate the basis thereof.
- 1.3. Pricing Bill of Quantity is completed in line with schedule if applicable.
- 1.4. Cost breakdown must be indicated.
- 1.5. Price escalation basis and formula must be indicated.
- 1.6. To facilitate like-for like comparison bidders must submit pricing strictly in accordance with this price schedule and not utilise a different format. Deviation from this pricing schedule could result in a bid being declared non-responsive.
- 1.7. Please note that should you have offered a discounted price(s), the HDA will only consider such price discount(s) in the final evaluation stage on an unconditional basis.
- 1.8. Bidders are to note that if price offered by the highest scoring bidder is not market related, the HDA may not award the contract to the Bidder. The HDA may:
 - 1.8.1. negotiate a market-related price with the Bidder scoring the highest points or cancel the RFP;
 - 1.8.2. if that Bidder does not agree to a market-related price, negotiate a market-related price with the Bidder scoring the second highest points or cancel the RFP; and
 - 1.8.3. if the Bidder scoring the second highest points does not agree to a market-related price, negotiate a market-related price with the Bidder scoring the third highest points or cancel the RFP.
 - 1.8.4. If a market-related price is not agreed with the Bidder scoring the third highest points, the HDA must cancel the RFP.

2 DISCLOSURE OF PRICES QUOTED

Bidders are to note that, on award of business, the HDA is required to publish the tendered prices and preferences points claimed of the successful and unsuccessful Bidders inter alia on the National Treasury e-Tender Publication Portal, (www.etenders.gov.za), as required per National Treasury.

3 OWNERSHIP OF DESIGN

- 1.1. The plans and design developed and to be provided by the HDA shall at all times remain the property of the HDA.]



4 SERVICE LEVELS

- 4.1. An experienced national account representative(s) is required to work with the HDA's procurement department. [No sales representatives are needed for individual department or locations]. Additionally, there shall be a minimal number of people, fully informed and accountable for this agreement.
- 4.2. The HDA will have quarterly reviews with the Service provider's account representative on an on-going basis.
- 4.3. The HDA reserves the right to request that any member of the Service provider's team involved on the HDA account be replaced if deemed not to be adding value for the HDA.
- 4.4. The Service provider guarantees that it will achieve a 100% [hundred per cent] service level on the following measures:
 - 4.4.1. Random checks on compliance with quality/quantity/specifications
 - 4.4.2. On time delivery.
- 4.5. The Service provider must provide a telephone number for customer service calls.
- 4.6. Failure of the Service provider to comply with stated service level requirements will give the HDA the right to cancel the contract in whole, without penalty to the HDA, giving 30 [thirty] calendar days' notice to the Service provider of its intention to do so.

Acceptance of Service Levels:

YES	
-----	--

5 TOTAL COST OF OWNERSHIP (TCO)

- 5.1. The HDA will strive to procure goods, services and works which contribute to its mission. In order to achieve this, the HDA must be committed to working with suppliers who share its goals of continuous improvement in service, quality and reduction of Total Cost of Ownership (TCO).
- 5.2. Bidders shall indicate whether they would be committed, for the duration of any contract which may be awarded through this RFP process, to participate with the HDA in its continuous improvement initiatives to reduce the total cost of ownership [TCO], which will reduce the overall cost of services provided by the HDA.



6. VALIDITY OF RETURNABLE DOCUMENTS

The successful Bidder will be required to ensure the validity of all returnable documents, including but not limited to its Tax compliance on CSD, for the duration of any contract emanating from this RFP. Should the Bidder be awarded the contract [the Agreement] and fail to present the HDA with such renewals as and when they become due, the HDA shall be entitled, in addition to any other rights and remedies that it may have in terms of the eventual Agreement, to terminate such Agreement forthwith without any liability and without prejudice to any claims which the HDA may have for damages against the Bidder.

SIGNED at _____ on this ____ day of _____ 2025

SIGNATURE OF WITNESSES

ADDRESS OF WITNESSES

1 _____

Name _____

2 _____

Name _____

SIGNATURE OF BIDDER'S AUTHORISED REPRESENTATIVE: _____

NAME: _____

DESIGNATION: _____



7. CERTIFICATE OF ACQUAINTANCE WITH RFP TERMS & CONDITIONS & APPLICABLE DOCUMENTS

By signing this certificate the Bidder is deemed to acknowledge that he/she has made himself/herself thoroughly familiar with, and agrees with all the conditions governing this RFP, including those contained in any printed form stated to form part hereof, including but not limited to the documents stated below and the HDA will recognise no claim for relief based on an allegation that the Bidder overlooked any such condition or failed properly to take it into account for the purpose of calculating tendered prices or any other purpose:

- | |
|--|
| 1. The HDA’s General Bid Conditions* |
| 2. Standard RFP Terms and Conditions for the supply of Goods or Services or Works to The HDA |

Should the Bidder find any terms or conditions stipulated in any of the relevant documents quoted in the RFP unacceptable, it should indicate which conditions are unacceptable and offer alternatives by written submission on its company letterhead, attached to its submitted Bid. Any such submission shall be subject to review by the HDA’s Legal department who shall determine whether the proposed alternative(s) are acceptable or otherwise, as the case may be. A material deviation from the Standard terms or conditions could result in disqualification.

Bidders accept that an obligation rests on them to clarify any uncertainties regarding any bid to which they intend to respond, before submitting the bid. The Bidder agrees that he/she will have no claim based on an allegation that any aspect of this RFP was unclear but in respect of which he/she failed to obtain clarity.

The bidder understands that his/her Bid will be disqualified if this Certificate of Acquaintance with RFP documents included in the RFP as a returnable document, is found not to be true and complete in every respect.

SIGNED at _____ on this _____ day of _____ 2025

SIGNATURE OF WITNESSES

ADDRESS OF WITNESSES

1 _____

Name _____



SIGNATURE OF BIDDER'S AUTHORISED REPRESENTATIVE: _____

NAME: _____

DESIGNATION: _____

8. GENERAL CONDITIONS

8.1. THE HDA'S TENDER FORMS

Bidders must sign and complete the HDA's Bid Forms and attach all the required documents. Failure by Bidders to adhere to this requirement may lead to their disqualification.

8.2. PRECEDENT

In case of any conflict with this RFP and Bidders response, this RFP and its briefing notes shall take precedence.

8.3. RESPONSE TO RFP-CONFIDENTIALITY

Response to RFPs must clearly indicate whether any information conveyed to or requested from the HDA is confidential or should be treated confidentially by the HDA. In the absence of any such clear indication in writing from a response to RFP, the HDA shall deem the response to RFP to have waived any right to confidentiality and treat such information as public in nature.

Where a Bidder at any stage during the RFP Process indicates to the HDA that information or any response to RFP requested from the HDA is or should be treated confidentially, the HDA shall treat such information or response to RFP confidentially, unless the HDA believes that to ensure the transparency and competitiveness of the RFP Process the content of the information or response to RFP should be conveyed to all Bidders, in which event it shall apply the following process:

- The HDA shall confirm with the Bidder whether the raising of confidentiality applies to the entire response to the RFP or only specific elements or sections of the response;



- Where confidentiality is maintained by the Bidder and the HDA is of the opinion that the information or response to RFP if made publicly available would affect the commercial interests of the Bidder or is commercially sensitive information, the HDA shall not release such information to other Bidders if providing such information or response to the RFP would prejudice the competitiveness and transparency of the RFP Process;
- Where the HDA is of the opinion that information provided is not commercially sensitive or would have no impact on the commercial interests of the relevant Bidder if released and fairness and transparency requires that such information be released to all Bidders, the HDA may:
 - i. inform the relevant Bidder of the necessity to release such information and/or response to RFP and request the Bidder to consent to the release thereof by the HDA; or
 - ii. obtain legal advice regarding the confidentiality of the relevant information and/or response to RFP and the legal ability of the HDA to release such information; or
 - iii. refrain from releasing the information and/or response to RFP, in which event the HDA shall not take account of the contents of such information in the evaluation of the relevant response to RFP.

The above procedures regarding confidentiality shall not apply to any information which is already public knowledge or available in the public domain or in the hands of the HDA or is required to be disclosed by any legal or regulatory requirements or order of any competent court, tribunal or forum.

8.4. RESPONSE TO THE RFP – RFP DISQUALIFICATION

Responses to RFP which do not comply with the RFP requirements, formalities, terms and conditions may be disqualified by the HDA from further participation in the RFP Process.

In particular (but without prejudice to the generality of the foregoing) the HDA may disqualify, at its sole discretion and without prejudice to any other remedy it may have, a Bidder where the Bidder, or any of its consortium/Joint venture members, subcontractors or advisors have committed any act of misrepresentation, bad faith or dishonest conduct in any of its dealings with or information provided to the HDA.



8.5. CORRUPTION, GIFTS AND PAYMENTS

Neither the Bidders to RFPs, its equity members, the sub-contractors, consortium members nor any of their agents, lenders or advisors shall directly or indirectly offer or give to any person in the employment of the HDA or any other Government official or any of the Advisory Team any gift or consideration of any kind as an inducement or reward for appointing a particular Bidder, or for showing or omitting to show favour or disfavour to any of the Bidders, its equity members or the sub-contractors in relation to the Project.

In the event that any of the prohibited practices contemplated under the above paragraph is committed, the HDA shall be entitled to terminate any Response to RFP's status and to prohibit such Bids to RFP, its equity members, its Sub Contractors and their agents, lenders and advisors from participating in any further part of the procurement of the Project.

8.6. INSURANCE

Unless specifically provided for in this RFP or draft contracts, Bidders will be required to submit with their Bid for services professional indemnity insurance and works insurance to an extent (if any) if insurance provided by the HDA may not be for the full cover required in terms of the relevant category listed in this RFP. The Bidder is advised to seek qualified advice regarding insurance.

8.7. NO CONTACT POLICY

Bidders may only contact the supply chain official of the HDA as per the terms of the Communication Structure established by this RFP, except in the case of pre-existing commercial relationships, in which case contact may be maintained only with respect thereto and, in making such contact, no party may make reference to the Project or this RFP.

8.8. CONFLICT OF INTEREST

No Bidder member, subcontractor or advisor of the response to RFP may be a member of or in any other way participate or be involved, either directly or indirectly in more than one response to RFP or response to RFP during any stage of the Project procurement process, but excluding specialist suppliers of systems and equipment, non-core service providers or financial or commercial institutions whose role is limited purely to lending money or advancing credit to the response to RFP. Bidders are to sign the declaration of interest form. In order to prevent the conflict or potential conflict of interest



between Lenders and Bidders to RFP, no advisors or the Contractor/s or Consortium/s to any response to RFP, consortium member or subcontractor may fulfil the role of arranger, underwriter and/or lead bank to the response to RFP. The HDA may disqualify the response to RFP from further participation in the event of a failure to comply with this provision. The HDA views the potential conflict of interest so great as to warrant the reduction of competition for advisory services.

8.9. COLLUSION AND CORRUPTION

Any Bidder shall, without prejudice to any other remedy available to the HDA, be disqualified, where the response to RFP –

- communicates to a person other than persons nominated by the HDA a material part of its response to RFP; or
- Enters into any Contract or arrangement with any other person or entity that it shall refrain from submitting a response to RFP to this RFP or as to any material part of its Response to RFP to this RFP (refer the prohibition contained in Section 4(1)(b)(iii) of the Competition Act 89 of 1998). . The Bidders represents that the Bidder has not, directly or indirectly, entered into any agreement, arrangement or understanding or any such like for the purpose of, with the intention to, enter into collusive Biding or with reasonable appreciation that, collusive any agreement, arrangement or understanding or any such like may result in or have the effect of collusive Biding. The Bidder undertakes that in the process of the Bid but prior to the HDA awarding the Bid to a preferred bidder become involved in or be aware of or do or caused to be done any agreement, arrangement or understanding or any such like for the purpose of or which may result in or have the effect of a collusive Bid, the Bidder will notify the HDA of such any agreement, arrangement or understanding or any such like.; or
- offers or agrees to pay or give any sum of money, inducement or valuable consideration directly or indirectly to any person for doing or having done, or causing, or having caused to be done any act or omission in relation to the RFP Process or any proposed response to RFP (provided nothing contained in this paragraph shall prevent a response to RFP from paying any market-related commission or bonus to its employees or contractors within the agreed terms of their employment or contract).

8.10. CONSORTIUM CHANGES

If exceptional circumstances should arise in which after the submission of the bid and after closing date of submission of bids, there is change in the composition of the members of the consortium, either through substitution or omission of any member of the consortium for the purpose of this RFP:



- The Bidder to RFP must notify the HDA in writing of the proposed changes supported by complete details of the material reasons for the changes, the parties impacted by the changes and the impact on the response to RFP.
- The HDA shall evaluate the reasons advanced by the Bidder for the requested changes to the Bidder structure and where the HDA is not satisfied that the reasons advanced are reasonable or material, refuse to accept the change and disqualify the response to RFP, or notify the Bidder in writing of its non-acceptance of the changes and require the Bidder to propose a suitable alternative to the HDA within 10 (TEN) days of its receipt of the decision of the HDA, upon receipt of which the HDA shall -
 - i. Evaluate the alternative proposed for suitability to the HDA, and where the alternative is accepted by the HDA, inform the Bidder in writing of such acceptance and the HDA shall reassess the response to RFP against the RFP requirements and criteria; or
 - ii. Where the alternative is not accepted by the HDA, inform the Bidder in writing of such non-acceptance as well as its disqualification from the RFP Process.
 - iii. Where the HDA is satisfied that the changes requested under (i) above are reasonable and material, the response to RFP, shall be allowed to effect the required changes and the HDA shall reassess the response to RFP against the RFP requirements and criteria.

8.11. COSTS OF RESPONSE TO THE RFP SUBMISSION

All costs and expenses associated with or incurred by the Bidder in relation to any stage of the Project, shall be borne by the Bidder. The HDA shall not be liable for any such costs or expenses or any claim for reimbursement of such costs or expenses.

To avoid doubt, the HDA shall not be liable for any samples submitted by the Bidder in support of their Responses to RFP and reserves the right not to return to them such samples and to dispose of them at its discretion.

8.12. RESPONSE TO THE RFP WARRANTY

Bidders must provide a warranty as part of their Responses to RFP that their Responses to RFP are true and correct in all respects, that it does not contain a misrepresentation of any kind and that the taxes of all members of the Bidder company, consortium members and or subcontractors are in order and none of the members are undergoing corruption or any criminal-related investigations or have any past convictions for fraud or corruption.

9. CONDITIONS OF TENDER

General

- | | | |
|--|---|--|
| Actions | 1 | The HDA's <i>Representative</i> and each <i>tenderer</i> submitting a tender shall act as stated in these Conditions of Tender and in a manner which is fair, equitable, transparent, competitive and cost-effective. |
| Interpretation | 2 | Terms shown in <i>italics</i> vary for each tender. The details of each term for this tender are identified in the Request for Tender / Scope of work/ specification. Terms shown in capital initials are defined terms in the appropriate conditions of contract. |
| | 3 | Any additional or amended requirements in the Scope of work/ specification, and additional requirements given in the Schedules in the <i>tender returnables</i> are deemed to be part of these Conditions of Tender. |
| | 4 | The Conditions of Tender and the Scope of work/ specification shall form part of any contract arising from this invitation to tender. |
| Communication | 5 | Each communication between the HDA and a <i>tenderer</i> shall be to or from the HDA's <i>Representative</i> only, and in a form that can be read, copied and recorded. Communication shall be in the English language. The HDA takes no responsibility for non-receipt of communications from or by a <i>tenderer</i> . |
| THE HDA's rights to accept or reject any tender | 6 | The HDA may accept or reject any variation, deviation, tender, or alternative tender, and may cancel the tender process and reject all tenders at any time prior to the formation of a contract. The HDA or the HDA's <i>Representative</i> will not accept or incur any liability to a <i>tenderer</i> for such cancellation and rejection, but will give reasons for the action. The HDA reserves the right to accept the whole or any part of any tender. |
| | 7 | After the cancellation of the tender process or the rejection of all tenders the HDA may abandon the proposed work and services, have it performed in any other manner, or re-issue a similar invitation to tender at any time. |

Tenderer's obligations

The *tenderer* shall comply with the following obligations when submitting a tender and shall:

- | | | |
|---|---|--|
| Eligibility | 1 | Submit a tender only if the <i>tenderer</i> complies with the criteria stated in the Scope of work/ specification. |
| Cost of tendering | 2 | Accept that the HDA will not compensate the <i>tenderer</i> for any costs incurred in the preparation and submission of a tender. |
| Check documents | 3 | Check the <i>tender documents</i> on receipt, including pages within them, and notify the HDA's <i>Representative</i> of any discrepancy or omissions in writing. |
| Copyright of documents | 4 | Use and copy the documents provided by the HDA only for the purpose of preparing and submitting a tender in response to this invitation. |
| Standardised specifications and other publications | 5 | Obtain, as necessary for submitting a tender, copies of the latest revision of standardised specifications and other publications, which are not attached but which are incorporated into the <i>tender documents</i> by reference. |
| | 6 | Acknowledge receipt of Addenda / Tender Briefing Notes to the <i>tender documents</i> , which the HDA's <i>Representative</i> may issue, and if necessary apply for an extension to the <i>deadline for tender submission</i> , in order to take the Addenda into account. |
| Site visit and / or clarification meeting | 7 | Attend a site visit and/or clarification meeting at which <i>tenderers</i> may familiarise themselves with the proposed work, services or supply, location, etc. and raise questions, if provided for in the Scope of work/ specification. Details of the meeting are stated in the RFP document, e-tender website and CIDB website. |
| Seek clarification | 8 | Request clarification of the <i>tender documents</i> , if necessary, by notifying the HDA's <i>Representative</i> earlier than the <i>closing time for clarification of queries</i> . |
| Insurance | 9 | Be informed of the risk that needs to be covered by insurance policy. The <i>tenderer</i> is advised to seek qualified advice regarding insurance. |



- Pricing the tender**
- 10 Include in the rates, prices, and the tendered total of the prices (if any) all duties, taxes (except VAT), and other levies payable by the successful *tenderer*. Such duties, taxes and levies are those applicable 14 days prior to the *deadline for tender submission*.
- 11 Show Value Added Tax (VAT) payable by The HDA separately as an addition to the tendered total of the prices.
- 12 Provide rates and prices that are fixed for the duration of the contract and not subject to adjustment except as provided for in the *conditions of contract*.
- 13 State the rates and Prices in South African Rand unless instructed otherwise as an additional condition in the Scope of work/ specification. The selected *conditions of contract* may provide for part payment in other currencies.
- Alterations to documents**
- 14 Not make any alterations or an addition to the tender documents, except to comply with instructions issued by the HDA's *Representative* or if necessary to correct errors made by the *tenderer*. All such alterations shall be initialled by all signatories to the tender. Corrections may not be made using correction fluid, correction tape or the like.
- Submitting a tender**
- 15 Submit a tender for providing the whole of the works, services or supply identified in the Contract Data unless stated otherwise as an additional condition in the Scope of work/ specification.
- NOTE:**
- 16 **Return the completed and signed *Tender document and SBD forms provided with the tender.***
- 17 **Submit the tender as an original and an electronic version which must be contained in USB clearly marked in the Bidders name as stated. Tenders may not be written in pencil but must be completed in ink.**
- 18 Sign and initial the original tender where indicated. The HDA will hold the signatory duly authorised and liable on behalf of the *tenderer*.
- 19 Seal the bid document in an envelope/package, the HDA's address and invitation to tender number stated in the Scope of work/ specification, **as well as the *tenderer's* name and contact address should be written on the envelope /package.** Where the tender is based on a



two envelop system tenderers must further indicate in the package whether the document is **envelope / package 1 or 2**. The **envelope/package must be marked “CONFIDENTIAL”**.

- 20 Accept that the HDA will not assume any responsibility for the misplacement or premature opening of the tender if the outer package is not sealed and marked as stated.

Note:

The HDA does not to receive BIDS by post, and takes no responsibility for delays in the postal system or in transit within or between the HDA offices.

The HDA does not to receive tenders by fax, the HDA takes no responsibility for difficulties in transmission caused by line or equipment faults.

Where tenders are sent via courier, the HDA takes no responsibility for tenders delivered to any other site than the tender office.

The HDA employees are not permitted to deposit a tender into the HDA tender box on behalf of a tenderer.

Closing time

- 25 Ensure that the HDA has received the tender at the stated address no later than the *deadline for tender submission*. Proof of posting will not be taken by the HDA as proof of delivery. The HDA will not accept a tender submitted telephonically, by Fax or E-mail unless stated otherwise in the tender document.
- 26 Accept that, if the HDA extends the *deadline for tender submission* for any reason, the requirements of these Conditions of Tender apply equally to the extended deadline.

Tender validity

- 27 Hold the tender(s) valid for acceptance by the HDA at any time within the *validity period* after the *deadline for tender submission*.
- 28 Extend the *validity period* for a specified additional period if the HDA requests the *tenderer* to extend it. A *tenderer* agreeing to the request will not be required or permitted to modify a tender, except to the extent the HDA may allow for the effects of inflation over the additional period.

Clarification of tender after submission

- 29 Provide clarification of a tender in response to a request to do so from the HDA's *Representative* during the evaluation of tenders. This may



include providing a breakdown of rates or Prices. No change in the total of the Prices or substance of the tender is sought, offered, or permitted except as required by the HDA's *Representative* to confirm the correction of arithmetical errors discovered in the evaluation of tenders. The total of the Prices stated by the *tenderer* as corrected by the HDA's *Representative* with the concurrence of the *tenderer*, shall be binding upon the *tenderer*

- | | | |
|------------------------------------|----|---|
| Submit bonds, policies etc. | 30 | If instructed by the HDA's <i>Representative</i> (before the formation of a contract), submit for the HDA's acceptance, the bonds, guarantees, policies and certificates of insurance required to be provided by the successful <i>tenderer</i> in terms of the <i>conditions of contract</i> . |
| | 31 | Undertake to check the final draft of the contract provided by the HDA's <i>Representative</i> , and sign the Form of Agreement all within the time required. |
| | 32 | Where an agent on behalf of a principal submits a tender, an authenticated copy of the authority to act as an agent must be submitted with the tender. |

THE HDA'S UNDERTAKINGS

The HDA, and the HDA's *Representative*, shall:

- | | | |
|---------------------------------|---|--|
| Respond to clarification | 1 | Respond to a request for clarification received earlier than the <i>closing time for clarification of queries</i> . The response is notified to all <i>tenderers</i> . |
| Issue Addenda | 2 | If necessary, issue to each <i>tenderer</i> from time to time during the period from the date of the Letter of Invitation until the <i>closing time for clarification of queries</i> , Addenda that may amend, amplify, or add to the <i>tender documents</i> . If a <i>tenderer</i> applies for an extension to the <i>deadline for tender submission</i> , in order to take Addenda into account in preparing a tender, the HDA may grant such an extension and the HDA's <i>Representative</i> shall notify the extension to all <i>tenderers</i> . |
| Return late tenders | 3 | Reject tenders received after the <i>deadline</i> . Tenders will be deemed late if they are not in the designated tender box at the date and time stipulated as the deadline for tender submission. |



Non-disclosure	4	Not disclose to <i>tenderers</i> , or to any other person not officially concerned with such processes, information relating to the evaluation and comparison of tenders and recommendations for the award of a contract.
Grounds for rejection	5	Consider rejecting a tender if there is any effort by a <i>tenderer</i> to influence the processing of tenders or contract award.
Disqualification	6	Instantly disqualify a <i>tenderer</i> (and his tender) if it is established that the <i>tenderer</i> offered an inducement to any person with a view to influencing the placing of a contract arising from this invitation to tender.
Test for responsiveness	7	Determine before detailed evaluation, whether each tender properly received <ul style="list-style-type: none"> • meets the requirements of these Conditions of Tender, • has been properly signed, and • is responsive to the requirements of the <i>tender documents</i>.
	8	Judge a responsive tender as one which conforms to all the terms, conditions, and specifications of the <i>tender documents</i> without material deviation or qualification. A material deviation or qualification is one which, in the HDA 's opinion would <ul style="list-style-type: none"> • detrimentally affect the scope, quality, or performance of the works, services or supply identified in the Contract Data, • change the HDA's or the <i>tenderer's</i> risks and responsibilities under the contract, or • affect the competitive position of other <i>tenderers</i> presenting responsive tenders, if it were to be rectified.
Non-responsive tenders	10	Reject a non-responsive tender, and not allow it to be subsequently made responsive by correction or withdrawal of the non-conforming deviation or reservation.
Arithmetical errors	11	Check responsive tenders for arithmetical errors, correcting them as follows: <ul style="list-style-type: none"> • Where there is a discrepancy between the amounts in figures and in words, the amount in words shall govern. • If a bill of quantities applies and there is a discrepancy between the rate and the line item total, resulting from multiplying the rate by the quantity, the rate as quoted shall govern. Where there is an obviously gross misplacement of the decimal point in the rate, the line item total as quoted shall govern, and the rate will be corrected.

- Where there is an error in the total of the Prices, either as a result of other corrections required by this checking process or in the *tenderer's* addition of prices, the total of the Prices, if any, will be corrected.
- 12 Reject a tender if the *tenderer* does not accept the corrected total of the Prices (if any).
- Evaluating the tender** 13 Evaluate responsive tenders in accordance with the procedure stated in the RFP / Scope of work/ specification.
- Clarification of a tender** 14 Obtain from a *tenderer* clarification of any matter in the tender which may not be clear or could give rise to ambiguity in a contract arising from this tender if the matter were not to be clarified.
- Acceptance of tender** 15 Notify the HDA's acceptance to the successful *tenderer* before the expiry of the *validity period*, or agreed additional period. Providing the notice of acceptance does not contain any qualifying statements, it will constitute the formation of a contract between the HDA and the successful *tenderer*.
- Notice to unsuccessful tenderers** 16 After the successful *tenderer* has acknowledged the HDA's notice of acceptance, notify other *tenderers* that their tenders have not been accepted, following the HDA's current procedures.
- Prepare contract documents** 17 Revise the contract documents issued by the HDA as part of the *tender documents* to take account of
- Addenda issued during the tender period,
 - inclusion of some of the *tender returnables*, and
 - other revisions agreed between THE HDA and the successful *tenderer*, before the issue of THE HDA's notice of acceptance (of the tender).
- Issue final contract** 18 Issue the final contract documents to the successful *tenderer* for acceptance within one week of the date of the HDA's notice of acceptance.
- Sign Form of Agreement** 19 Arrange for authorised signatories of both parties to complete and sign the original Form of Agreement within two weeks of the date of the HDA's notice of acceptance of the tender. If either party requires the signatories to initial every page of the contract documents, the signatories for the other party shall comply with the request.



Annexure: 1

SCOPE OF WORK

The Service Provider is to ensure a safe, well maintained and hygienic environment for persons authorised to occupy the Transitional Relocation Area.

The repairs and maintenance will be done on an “as and when required” basis and subject to prior approval by the HDA (Project Manager) and the Department of Infrastructure: Human Settlements Branch.

The following work shall be expected from the contractor: -

Repairs and Maintenance
<ul style="list-style-type: none"> 60 non-flush portable chemical toilets and honey sucked 3 x a week.
<ul style="list-style-type: none"> Daily cleaning and sanitising of 60 non-flush portable chemical toilets (cleaning materials to be provided by the Service Provider).
<ul style="list-style-type: none"> Daily cleaning, sanitising, and maintenance of 6 ablution blocks. (concrete floor supporting the 60 non-flush portable chemical toilets and 12 concrete wash troughs)
<ul style="list-style-type: none"> Emptying of 12 X 6000 litre wastewater tanks and the appropriate disposal of wastewater, in keeping with the applicable bylaws and environmental standards.
<ul style="list-style-type: none"> Emptying out of 72 000 litres of grey water weekly from septic tanks and disposing thereof.
<ul style="list-style-type: none"> Ad-Hoc sewer jet cleaning services This will be done as and when requested by the HDA. In each instance, a request will be issued, thereafter a quote to be submitted in writing to the HDA. The HDA will thereafter provide written approval to proceed with the job.

- Service provider to provide service 7 days in the week including Saturdays and Sundays 24 months period.
- Service provider is to keep an up-to-date incident book of all repairs required and findings on accountability for the duration of the contract.
- Service provider will be required to manage the implementation of labour-intensive projects in terms of the EPWP as and when funding becomes available. (a separate contract will be entered into). Daily registers to be signed by the labourers and Supervisor and submitted with invoice and to EPWP projects.
- Plan of ablution is for illustrative purposes is attached as “**ablution facilities layout**”.



General

- Coordinate maintenance between Stakeholders.
- Supporting documents for all maintenance and repairs, must be signed off by the HDA. (A copy must be submitted when presenting an invoice.)
- Time sheets of labourers to be done daily on site. (Time sheets to be submitted when submitting the invoice).
- Maintenance and repair work to be done on an “as required” basis and only after prior approval from the HDA/Client.
- EPWP monthly reports to be submitted as required by Dol.
- To attend the monthly site meetings either via Teams or face to face.

Duration

The anticipated timeframe for the completion of this project is **24 Months**.



FORM C: TENDER FORM- Volume 2 (Envelop 2/ Package 2)

CURRENT TENDER DETAILS	
Request number:	HDA/HO/2024/056
Request for Tender:	THE APPOINTMENT OF A SERVICE PROVIDER FOR THE SUPPLY AND MAINTENANCE OF 60 NON-FLUSH PORTABLE CHEMICAL TOILETS FOR THE TEMPORARY RELOCATION AREA (TRA) WELMOED TRANSITIONAL RELOCATION AREA FOR A PERIOD OF 24 MONTHS

I / We _____

(Insert Name of Tendering Entity)

Of

(Full address)

Conducting business under the style or title of:

Represented by:

in my capacity as:

being duly authorised thereto by a Resolution of the Board of Directors / Certificate of Partners, Members or Participants, as the case may be, dated _____, a certified copy of which is annexed hereto, hereby offer to undertake and complete the above-mentioned work (hereinafter called "the WORKS") at the prices quoted in the bills of quantities / schedule of quantities or, where these do not form part of the contract, at a lump sum, in accordance with the terms set forth in the accompanying letter(s) reference _____ and dated _____ (if any) and the documents listed in the accompanying schedule of tender documents for the sum of R _____ (amount in words), (All applicable taxes included)



- N.B.** (i) In the event of any discrepancy, the amount in words will take precedence over the amount in figures.
- (ii) Where items in the priced bills of quantities submitted with the tender for the WORKS other than architectural building work are incorrectly extended arithmetically, the unit rate will be treated as decisive.
- (iii) In tenders for architectural building work the total amount will be treated as decisive. If amounts for individual items cannot be reconciled with the total amount, the amounts for individual items shall be adjusted to the satisfaction of the HDA to conform to the total amount.

The following list of persons are hereby authorised to negotiate on behalf of the abovementioned entity, should THE HDA decide to enter into Post Tender Negotiations with shortlisted bidder(s).

FULL NAME (S)	CAPACITY:	SIGNATURE:

I/We hereby offer to supply the abovementioned Services at the prices quoted in the schedule of prices in accordance with the terms set forth in the documents listed in the accompanying schedule of RFP documents.

I / We accept that should the HDA accept my / our tender and issue me / us with the notice of acceptance, this tender and, if any, its covering letter and any subsequent exchange of correspondence together with the HDA acceptance thereof, such acceptance shall be subject to a written contract to be concluded between the HDA and me / us.

I / We undertake to produce acceptable documentary proof of the necessary coverage for Workmen's Compensation, Securities and Insurance within **30 (thirty)** working days of notification of awarding of the



contract, and to sign a formal contract if called upon by the HDA to do so within **7 (seven)** working days of notification by the HDA that the contract documents are ready for signature.

I / We undertake to complete the whole of the WORKS within _____
(in words) from the date of notification to me / us of acceptance of the tender, subject to completion in stages if and as laid down in the project specification and to such extensions of time as may be granted. Failing completion of the WORKS or any stage of the WORKS within the period(s) stipulated or by such extended date(s) as may be allowed by the HDA I / we shall pay to the HDA in terms of the Conventional Penalties Act 15 of 1962, the penalty for which provision is made in the project specification. The ordering of any alterations, extras, additions or omissions shall not in any way prejudice the HDA claim for such penalty.

Application for relief from the obligation to pay a penalty will be considered by the HDA, but shall be granted only if I / we can prove to the reasonable satisfaction of the HDA that the penalty is out of proportion to the prejudice suffered by the HDA by reason of the act or omission in respect of which the penalty was stipulated.

I / We declare that this tender holds good until _____ **(a minimum period of 120 Business days from closing date is required).**

I / We further agree that if, after I / we have been notified of the acceptance of my / our tender, I / we fail to enter into a formal contract if called upon to do so, or fail to furnish satisfactory security for the due and proper completion of the WORKS, the HDA may, without prejudice to any other legal remedy which it may have, recover from me / us any expense to which it may have been put in calling for tenders afresh and / or having to accept any less favourable tender.

I / We declare that, being a company / partnership / close corporation / joint venture, I / we have duly completed the annexe hereto and certified it as correct.

The several documents involved are to be taken as complementary to each other. In the event of any conflict between the content of any of the documents listed in the schedule of tender documents (other than the project specification) and the project specification, the latter shall prevail. In the event of any conflict between the letter that accompanies the tender or other relevant correspondence and the contents of the documents listed in the schedule of tender documents (including the project specification) such letter or correspondence shall prevail.



I/we agree that non-compliance with any of the material terms of this RFP, including those mentioned above, will constitute a material breach of contract and provide the HDA with cause for cancellation.

THUS DONE and SIGNED at _____

on this _____ day of _____

DULY AUTHORISED SIGNATORY(IES) WITNESSES

- | | | | |
|----|-------|----|-------|
| 1. | _____ | 1. | _____ |
| 2. | _____ | 2. | _____ |
| 3. | _____ | 3. | _____ |

Annexure: 2

PRICING SCHEDULE

<i>Item</i>	<i>Description of Service</i>	<i>Duration</i>	<i>Amount in (R)</i>
1	Renting of 60 non-flush portable chemical toilets and honey sucked 3 x a week.	24 Months	
2	Daily cleaning and sanitising of 60 non-flush portable chemical toilets (cleaning materials to be provided by the Service Provider).	24 Months	
3	Daily cleaning, sanitising, and maintenance of 6 ablution blocks. (concrete floor supporting the 60 non-flush portable chemical toilets and 12 concrete wash troughs)	24 Months	
4	Employ 6 local labourers and 1 supervisor.	24 Months	
5	Emptying of 12 X 6000 litre wastewater tanks and the appropriate disposal of wastewater, in keeping with the applicable bylaws and environmental standards.	24 Months	
6	Emptying out of 72 000 litres of grey water weekly from septic tanks and disposing thereof.	24 Months	
7	Total VAT Exclusive		
8	VAT 15%		
9	Total VAT Inclusive		
As and when required services		Rate	
10	Ad-Hoc sewer jet cleaning services This will be done as and when requested by the HDA. In each instance, a request will be issued, thereafter a quote to be submitted in writing to the HDA. The HDA will thereafter provide written approval to proceed with the job.		



- Service provider to provide service 7 days in the week including Saturdays and Sundays 365 days (1 year) for 24-month period.
- Service provider is to keep an up-to-date incident book of all repairs required and findings on accountability for the duration of the contract.
- Service provider will be required to manage the implementation of labour-intensive projects in terms of the EPWP as and when funding becomes available. (a separate contract will be entered into).
- Plan of ablution is for illustrative purposes is attached as ablution facilities layout.
- The Service provider will be required to subcontract the following components of the Repairs and Maintenance Scope of Work

SBD1

PART A INVITATION TO BID

YOU ARE HEREBY INVITED TO BID FOR REQUIREMENTS OF THE (NAME OF DEPARTMENT/ PUBLIC ENTITY)					
BID NUMBER:	HDA/HO/2024/056	CLOSING DATE:	02 APRIL 2025	CLOSING TIME:	11:00
DESCRIPTION	THE APPOINTMENT OF A SERVICE PROVIDER FOR THE SUPPLY AND MAINTENANCE OF 60 NON-FLUSH PORTABLE CHEMICAL TOILETS FOR THE TEMPORARY RELOCATION AREA (TRA) WELMOED TRANSITIONAL RELOCATION AREA FOR A PERIOD OF 24 MONTHS.				
BID RESPONSE DOCUMENTS MAY BE DEPOSITED IN THE BID BOX SITUATED AT (STREET ADDRESS)					
THE HOUSING DEVELOPMENT AGENCY					
Reception Area					
04 Kikuyu Road					
Sunninghill, 2157					
BIDDING PROCEDURE ENQUIRIES MAY BE DIRECTED TO			TECHNICAL ENQUIRIES MAY BE DIRECTED TO:		
CONTACT PERSON			CONTACT PERSON		
TELEPHONE NUMBER	0115441000		TELEPHONE NUMBER	0115441000	
FACSIMILE NUMBER			FACSIMILE NUMBER		
E-MAIL ADDRESS	Tender3@thehda.co.za		E-MAIL ADDRESS	Tender3@thehda.co.za	
SUPPLIER INFORMATION					
NAME OF BIDDER					
POSTAL ADDRESS					
STREET ADDRESS					
TELEPHONE NUMBER	CODE		NUMBER		
CELLPHONE NUMBER					
FACSIMILE NUMBER	CODE		NUMBER		
E-MAIL ADDRESS					
VAT REGISTRATION NUMBER					
SUPPLIER COMPLIANCE STATUS	TAX COMPLIANCE SYSTEM PIN:		OR	CENTRAL SUPPLIER DATABASE No:	MAAA
7 ARE YOU THE ACCREDITED REPRESENTATIVE IN SOUTH AFRICA FOR THE GOODS /SERVICES OFFERED?	<input type="checkbox"/> Yes <input type="checkbox"/> No [IF YES ENCLOSE PROOF]		8 ARE YOU A FOREIGN BASED SUPPLIER FOR THE GOODS /SERVICES OFFERED?	<input type="checkbox"/> Yes <input type="checkbox"/> No [IF YES, ANSWER THE QUESTIONNAIRE BELOW]	
QUESTIONNAIRE TO BIDDING FOREIGN SUPPLIERS					
IS THE ENTITY A RESIDENT OF THE REPUBLIC OF SOUTH AFRICA (RSA)?			<input type="checkbox"/> YES <input type="checkbox"/> NO		
DOES THE ENTITY HAVE A BRANCH IN THE RSA?			<input type="checkbox"/> YES <input type="checkbox"/> NO		
DOES THE ENTITY HAVE A PERMANENT ESTABLISHMENT IN THE RSA?			<input type="checkbox"/> YES <input type="checkbox"/> NO		
DOES THE ENTITY HAVE ANY SOURCE OF INCOME IN THE RSA?			<input type="checkbox"/> YES <input type="checkbox"/> NO		
IS THE ENTITY LIABLE IN THE RSA FOR ANY FORM OF TAXATION?			<input type="checkbox"/> YES <input type="checkbox"/> NO		
IF THE ANSWER IS "NO" TO ALL OF THE ABOVE, THEN IT IS NOT A REQUIREMENT TO REGISTER FOR A TAX COMPLIANCE STATUS SYSTEM PIN CODE FROM THE SOUTH AFRICAN REVENUE SERVICE (SARS) AND IF NOT REGISTER AS PER 2.3 BELOW.					

PART B TERMS AND CONDITIONS FOR BIDDING

1. BID SUBMISSION:
<p>1.1. BIDS MUST BE DELIVERED BY THE STIPULATED TIME TO THE CORRECT ADDRESS. LATE BIDS WILL NOT BE ACCEPTED FOR CONSIDERATION.</p> <p>1.2. ALL BIDS MUST BE SUBMITTED ON THE OFFICIAL FORMS PROVIDED (NOT TO BE RE-TYPED) OR IN THE MANNER PRESCRIBED IN THE BID DOCUMENT.</p> <p>1.3. THIS BID IS SUBJECT TO THE PREFERENTIAL PROCUREMENT POLICY FRAMEWORK ACT, 2000 AND THE PREFERENTIAL PROCUREMENT REGULATIONS, THE GENERAL CONDITIONS OF CONTRACT (GCC) AND, IF APPLICABLE, ANY OTHER SPECIAL CONDITIONS OF CONTRACT.</p> <p>1.4. THE SUCCESSFUL BIDDER WILL BE REQUIRED TO FILL IN AND SIGN A WRITTEN CONTRACT FORM (SBD7).</p>
2. TAX COMPLIANCE REQUIREMENTS
<p>2.1 BIDDERS MUST ENSURE COMPLIANCE WITH THEIR TAX OBLIGATIONS.</p> <p>2.2 BIDDERS ARE REQUIRED TO SUBMIT THEIR UNIQUE PERSONAL IDENTIFICATION NUMBER (PIN) ISSUED BY SARS TO ENABLE THE ORGAN OF STATE TO VERIFY THE TAXPAYER'S PROFILE AND TAX STATUS.</p> <p>2.3 APPLICATION FOR TAX COMPLIANCE STATUS (TCS) PIN MAY BE MADE VIA E-FILING THROUGH THE SARS WEBSITE WWW.SARS.GOV.ZA.</p> <p>2.4 BIDDERS MAY ALSO SUBMIT A PRINTED TCS CERTIFICATE TOGETHER WITH THE BID.</p> <p>2.5 IN BIDS WHERE CONSORTIA / JOINT VENTURES / SUB-CONTRACTORS ARE INVOLVED; EACH PARTY MUST SUBMIT A SEPARATE TCS CERTIFICATE / PIN / CSD NUMBER.</p> <p>2.6 WHERE NO TCS PIN IS AVAILABLE BUT THE BIDDER IS REGISTERED ON THE CENTRAL SUPPLIER DATABASE (CSD), A CSD NUMBER MUST BE PROVIDED.</p> <p>2.7 NO BIDS WILL BE CONSIDERED FROM PERSONS IN THE SERVICE OF THE STATE, COMPANIES WITH DIRECTORS WHO ARE PERSONS IN THE SERVICE OF THE STATE, OR CLOSE CORPORATIONS WITH MEMBERS PERSONS IN THE SERVICE OF THE STATE."</p>

NB: FAILURE TO PROVIDE / OR COMPLY WITH ANY OF THE ABOVE PARTICULARS MAY RENDER THE BID INVALID.

SIGNATURE OF BIDDER:

CAPACITY UNDER WHICH THIS BID IS SIGNED:
(Proof of authority must be submitted e.g. company resolution)

DATE:

BIDDER'S DISCLOSURE

1. PURPOSE OF THE FORM

Any person (natural or juristic) may make an offer or offers in terms of this invitation to bid. In line with the principles of transparency, accountability, impartiality, and ethics as enshrined in the Constitution of the Republic of South Africa and further expressed in various pieces of legislation, it is required for the bidder to make this declaration in respect of the details required hereunder.

Where a person/s are listed in the Register for Tender Defaulters and / or the List of Restricted Suppliers, that person will automatically be disqualified from the bid process.

2. Bidder's declaration

2.1 Is the bidder, or any of its directors / trustees / shareholders / members / partners or any person having a controlling interest¹ in the enterprise, employed by the state? **YES/NO**

2.1.1 If so, furnish particulars of the names, individual identity numbers, and, if applicable, state employee numbers of sole proprietor/ directors / trustees / shareholders / members/ partners or any person having a controlling interest in the enterprise, in table below.

Full Name	Identity Number	Name of State institution

2.2 Do you, or any person connected with the bidder, have a relationship with any person who is employed by the procuring institution? **YES/NO**

¹ the power, by one person or a group of persons holding the majority of the equity of an enterprise, alternatively, the person/s having the deciding vote or power to influence or to direct the course and decisions of the enterprise.

2.2.1 If so, furnish particulars:

.....

2.3 Does the bidder or any of its directors / trustees / shareholders / members / partners or any person having a controlling interest in the enterprise have any interest in any other related enterprise whether or not they are bidding for this contract?
YES/NO

2.3.1 If so, furnish particulars:

.....

3 DECLARATION

I, _____ the _____ undersigned, (name)..... in submitting the accompanying bid, do hereby make the following statements that I certify to be true and complete in every respect:

- 3.1 I have read and I understand the contents of this disclosure;
- 3.2 I understand that the accompanying bid will be disqualified if this disclosure is found not to be true and complete in every respect;
- 3.3 The bidder has arrived at the accompanying bid independently from, and without consultation, communication, agreement or arrangement with any competitor. However, communication between partners in a joint venture or consortium² will not be construed as collusive bidding.
- 3.4 In addition, there have been no consultations, communications, agreements or arrangements with any competitor regarding the quality, quantity, specifications, prices, including methods, factors or formulas used to calculate prices, market allocation, the intention or decision to submit or not to submit the bid, bidding with the intention not to win the bid and conditions or delivery particulars of the products or services to which this bid invitation relates.
- 3.4 The terms of the accompanying bid have not been, and will not be, disclosed by the bidder, directly or indirectly, to any competitor, prior to the date and time of the official bid opening or of the awarding of the contract.
- 3.5 There have been no consultations, communications, agreements or arrangements made by the bidder with any official of the procuring institution in relation to this procurement process prior to and during the bidding process except to provide clarification on the bid submitted where so required by the institution; and the bidder was not involved in the drafting of the specifications or terms of reference for this bid.

1 Joint venture or Consortium means an association of persons for the purpose of combining their expertise, property, capital, efforts, skill and knowledge in an activity for the execution of a contract.

3.6 I am aware that, in addition and without prejudice to any other remedy provided to combat any restrictive practices related to bids and contracts, bids that are suspicious will be reported to the Competition Commission for investigation and possible imposition of administrative penalties in terms of section 59 of the Competition Act No 89 of 1998 and or may be reported to the National Prosecuting Authority (NPA) for criminal investigation and or may be restricted from conducting business with the public sector for a period not exceeding ten (10) years in terms of the Prevention and Combating of Corrupt Activities Act No 12 of 2004 or any other applicable legislation.

I CERTIFY THAT THE INFORMATION FURNISHED IN PARAGRAPHS 1, 2 and 3 ABOVE IS CORRECT.

I ACCEPT THAT THE STATE MAY REJECT THE BID OR ACT AGAINST ME IN TERMS OF PARAGRAPH 6 OF PFMA SCM INSTRUCTION 03 OF 2021/22 ON PREVENTING AND COMBATING ABUSE IN THE SUPPLY CHAIN MANAGEMENT SYSTEM SHOULD THIS DECLARATION PROVE TO BE FALSE.

.....
Signature	Date
.....
Position	Name of bidder

**PREFERENCE POINTS CLAIM FORM IN TERMS OF THE PREFERENTIAL
PROCUREMENT REGULATIONS 2022**

This preference form must form part of all tenders invited. It contains general information and serves as a claim form for preference points for specific goals.

NB: BEFORE COMPLETING THIS FORM, TENDERERS MUST STUDY THE GENERAL CONDITIONS, DEFINITIONS AND DIRECTIVES APPLICABLE IN RESPECT OF THE TENDER AND PREFERENTIAL PROCUREMENT REGULATIONS, 2022

1. GENERAL CONDITIONS

- 1.1 The following preference point systems are applicable to invitations to tender:
- the 80/20 system for requirements with a Rand value of up to R50 000 000 (all applicable taxes included); and
 - the 90/10 system for requirements with a Rand value above R50 000 000 (all applicable taxes included).

1.2 To be completed by the organ of state

- a) The applicable preference point system for this tender is the **80/20** preference point system.
- b) The **80/20 preference point system** will be applicable in this tender. The lowest/highest acceptable tender will be used to determine the accurate system once tenders are received.

1.3 Points for this tender (even in the case of a tender for income-generating contracts) shall be awarded for:

- (a) Price; and
- (b) Specific Goals.

1.4 To be completed by the organ of state:

The maximum points for this tender are allocated as follows:

	POINTS
PRICE	80
SPECIFIC GOALS	20
Total points for Price and SPECIFIC GOALS	100

1.5 Failure on the part of a tenderer to submit proof or documentation required in terms of

this tender to claim points for specific goals with the tender, will be interpreted to mean that preference points for specific goals are not claimed.

- 1.6 The organ of state reserves the right to require of a tenderer, either before a tender is adjudicated or at any time subsequently, to substantiate any claim in regard to preferences, in any manner required by the organ of state.

2. DEFINITIONS

- (a) **“tender”** means a written offer in the form determined by an organ of state in response to an invitation to provide goods or services through price quotations, competitive tendering process or any other method envisaged in legislation;
- (b) **“price”** means an amount of money tendered for goods or services, and includes all applicable taxes less all unconditional discounts;
- (c) **“rand value”** means the total estimated value of a contract in Rand, calculated at the time of bid invitation, and includes all applicable taxes;
- (d) **“tender for income-generating contracts”** means a written offer in the form determined by an organ of state in response to an invitation for the origination of income-generating contracts through any method envisaged in legislation that will result in a legal agreement between the organ of state and a third party that produces revenue for the organ of state, and includes, but is not limited to, leasing and disposal of assets and concession contracts, excluding direct sales and disposal of assets through public auctions; and
- (e) **“the Act”** means the Preferential Procurement Policy Framework Act, 2000 (Act No. 5 of 2000).

3. FORMULAE FOR PROCUREMENT OF GOODS AND SERVICES

3.1. POINTS AWARDED FOR PRICE

3.1.1 THE 80/20 PREFERENCE POINT SYSTEMS

A maximum of 80 points is allocated for price on the following basis:

80/20

$$Ps = 80 \left(1 - \frac{Pt - Pmin}{Pmin} \right)$$

Where

Ps = Points scored for price of tender under consideration

Pt = Price of tender under consideration

Pmin = Price of lowest acceptable tender

3.2. FORMULAE FOR DISPOSAL OR LEASING OF STATE ASSETS AND INCOME GENERATING PROCUREMENT

3.2.1. POINTS AWARDED FOR PRICE

A maximum of 80 points is allocated for price on the following basis:

80/20

$$P_s = 80 \left(1 + \frac{P_t - P_{max}}{P_{max}} \right)$$

Where

- Ps = Points scored for price of tender under consideration
- Pt = Price of tender under consideration
- Pmax = Price of highest acceptable tender

4. POINTS AWARDED FOR SPECIFIC GOALS

- 4.1. In terms of Regulation 4(2); 5(2); 6(2) and 7(2) of the Preferential Procurement Regulations, preference points must be awarded for specific goals stated in the tender. For the purposes of this tender the tenderer will be allocated points based on the goals stated in table 1 below as may be supported by proof/ documentation stated in the conditions of this tender:
- 4.2. In cases where organs of state intend to use Regulation 3(2) of the Regulations, which states that, if it is unclear whether the 80/20 or 90/10 preference point system applies, an organ of state must, in the tender documents, stipulate in the case of—
 - (a) an invitation for tender for income-generating contracts, that either the 80/20 or 90/10 preference point system will apply and that the highest acceptable tender will be used to determine the applicable preference point system; or
 - (b) any other invitation for tender, that either the 80/20 or 90/10 preference point system will apply and that the lowest acceptable tender will be used to determine the applicable preference point system,
 then the organ of state must indicate the points allocated for specific goals for both the 90/10 and 80/20 preference point system.

Table 1: Specific goals for the tender and points claimed are indicated per the table

below.

(Note to organs of state: Where either the 80/20 preference point system is applicable, corresponding points must also be indicated as such.)

Note to tenderers: The tenderer must indicate how they claim points for each preference point system.)

The specific goals allocated points in terms of this tender	Number of points allocated (80/20 system) (To be completed by the organ of state)	Number of points claimed (80/20 system) (Tenderer to indicate by a cross or a tick against the selected specific goals)
Black women (5)		
75% - 100%	5	
51% - 74.99%	3	
Below 51%	1	
Historically Disadvantaged South Africans* (maximum Points = 15)		
Youth	5	
HDSA	3	
Disabled People	5	
Military Veterans	2	

DECLARATION WITH REGARD TO COMPANY/FIRM

4.3. Name of company/firm.....

4.4. Company registration number:

4.5. TYPE OF COMPANY/ FIRM

- Partnership/Joint Venture / Consortium
- One-person business/sole propriety
- Close corporation
- Public Company
- Personal Liability Company
- (Pty) Limited
- Non-Profit Company
- State Owned Company

[TICK APPLICABLE BOX]

4.6. I, the undersigned, who is duly authorised to do so on behalf of the company/firm, certify that the points claimed, based on the specific goals as advised in the tender, qualifies the company/ firm for the preference(s) shown and I acknowledge that:

- i) The information furnished is true and correct;
- ii) The preference points claimed are in accordance with the General Conditions as indicated in paragraph 1 of this form;

- iii) In the event of a contract being awarded as a result of points claimed as shown in paragraphs 1.4 and 4.2, the contractor may be required to furnish documentary proof to the satisfaction of the organ of state that the claims are correct;
- iv) If the specific goals have been claimed or obtained on a fraudulent basis or any of the conditions of contract have not been fulfilled, the organ of state may, in addition to any other remedy it may have –
 - (a) disqualify the person from the tendering process;
 - (b) recover costs, losses or damages it has incurred or suffered as a result of that person’s conduct;
 - (c) cancel the contract and claim any damages which it has suffered as a result of having to make less favourable arrangements due to such cancellation;
 - (d) recommend that the tenderer or contractor, its shareholders and directors, or only the shareholders and directors who acted on a fraudulent basis, be restricted from obtaining business from any organ of state for a period not exceeding 10 years, after the *audi alteram partem* (hear the other side) rule has been applied; and
 - (e) forward the matter for criminal prosecution, if deemed necessary.

 SIGNATURE(S) OF TENDERER(S)
SURNAME AND NAME:
DATE:
ADDRESS:

THE NATIONAL TREASURY

Republic of South Africa



GOVERNMENT PROCUREMENT: GENERAL CONDITIONS OF CONTRACT

July 2010

GOVERNMENT PROCUREMENT
GENERAL CONDITIONS OF CONTRACT
July 2010

NOTES

The purpose of this document is to:

- (i) Draw special attention to certain general conditions applicable to government bids, contracts and orders; and
- (ii) To ensure that clients be familiar with regard to the rights and obligations of all parties involved in doing business with government.

In this document words in the singular also mean in the plural and vice versa and words in the masculine also mean in the feminine and neuter.

- The General Conditions of Contract will form part of all bid documents and may not be amended.
- Special Conditions of Contract (SCC) relevant to a specific bid, should be compiled separately for every bid (if applicable) and will supplement the General Conditions of Contract. Whenever there is a conflict, the provisions in the SCC shall prevail.

TABLE OF CLAUSES

1. Definitions
2. Application
3. General
4. Standards
5. Use of contract documents and information; inspection
6. Patent rights
7. Performance security
8. Inspections, tests and analysis
9. Packing
10. Delivery and documents
11. Insurance
12. Transportation
13. Incidental services
14. Spare parts
15. Warranty
16. Payment
17. Prices
18. Contract amendments
19. Assignment
20. Subcontracts
21. Delays in the supplier's performance
22. Penalties
23. Termination for default
24. Dumping and countervailing duties
25. Force Majeure
26. Termination for insolvency
27. Settlement of disputes
28. Limitation of liability
29. Governing language
30. Applicable law
31. Notices
32. Taxes and duties
33. National Industrial Participation Programme (NIPP)
34. Prohibition of restrictive practices

General Conditions of Contract

1. Definitions

1. The following terms shall be interpreted as indicated:
 - 1.1 “Closing time” means the date and hour specified in the bidding documents for the receipt of bids.
 - 1.2 “Contract” means the written agreement entered into between the purchaser and the supplier, as recorded in the contract form signed by the parties, including all attachments and appendices thereto and all documents incorporated by reference therein.
 - 1.3 “Contract price” means the price payable to the supplier under the contract for the full and proper performance of his contractual obligations.
 - 1.4 “Corrupt practice” means the offering, giving, receiving, or soliciting of any thing of value to influence the action of a public official in the procurement process or in contract execution.
 - 1.5 "Countervailing duties" are imposed in cases where an enterprise abroad is subsidized by its government and encouraged to market its products internationally.
 - 1.6 “Country of origin” means the place where the goods were mined, grown or produced or from which the services are supplied. Goods are produced when, through manufacturing, processing or substantial and major assembly of components, a commercially recognized new product results that is substantially different in basic characteristics or in purpose or utility from its components.
 - 1.7 “Day” means calendar day.
 - 1.8 “Delivery” means delivery in compliance of the conditions of the contract or order.
 - 1.9 “Delivery ex stock” means immediate delivery directly from stock actually on hand.
 - 1.10 “Delivery into consignees store or to his site” means delivered and unloaded in the specified store or depot or on the specified site in compliance with the conditions of the contract or order, the supplier bearing all risks and charges involved until the supplies are so delivered and a valid receipt is obtained.
 - 1.11 "Dumping" occurs when a private enterprise abroad market its goods on own initiative in the RSA at lower prices than that of the country of origin and which have the potential to harm the local industries in the

RSA.

- 1.12 "Force majeure" means an event beyond the control of the supplier and not involving the supplier's fault or negligence and not foreseeable. Such events may include, but is not restricted to, acts of the purchaser in its sovereign capacity, wars or revolutions, fires, floods, epidemics, quarantine restrictions and freight embargoes.
- 1.13 "Fraudulent practice" means a misrepresentation of facts in order to influence a procurement process or the execution of a contract to the detriment of any bidder, and includes collusive practice among bidders (prior to or after bid submission) designed to establish bid prices at artificial non-competitive levels and to deprive the bidder of the benefits of free and open competition.
- 1.14 "GCC" means the General Conditions of Contract.
- 1.15 "Goods" means all of the equipment, machinery, and/or other materials that the supplier is required to supply to the purchaser under the contract.
- 1.16 "Imported content" means that portion of the bidding price represented by the cost of components, parts or materials which have been or are still to be imported (whether by the supplier or his subcontractors) and which costs are inclusive of the costs abroad, plus freight and other direct importation costs such as landing costs, dock dues, import duty, sales duty or other similar tax or duty at the South African place of entry as well as transportation and handling charges to the factory in the Republic where the supplies covered by the bid will be manufactured.
- 1.17 "Local content" means that portion of the bidding price which is not included in the imported content provided that local manufacture does take place.
- 1.18 "Manufacture" means the production of products in a factory using labour, materials, components and machinery and includes other related value-adding activities.
- 1.19 "Order" means an official written order issued for the supply of goods or works or the rendering of a service.
- 1.20 "Project site," where applicable, means the place indicated in bidding documents.
- 1.21 "Purchaser" means the organization purchasing the goods.
- 1.22 "Republic" means the Republic of South Africa.
- 1.23 "SCC" means the Special Conditions of Contract.
- 1.24 "Services" means those functional services ancillary to the supply of the goods, such as transportation and any other incidental services, such as installation, commissioning, provision of technical assistance, training, catering, gardening, security, maintenance and other such

obligations of the supplier covered under the contract.

1.25 “Written” or “in writing” means handwritten in ink or any form of electronic or mechanical writing.

2. Application

2.1 These general conditions are applicable to all bids, contracts and orders including bids for functional and professional services, sales, hiring, letting and the granting or acquiring of rights, but excluding immovable property, unless otherwise indicated in the bidding documents.

2.2 Where applicable, special conditions of contract are also laid down to cover specific supplies, services or works.

2.3 Where such special conditions of contract are in conflict with these general conditions, the special conditions shall apply.

3. General

3.1 Unless otherwise indicated in the bidding documents, the purchaser shall not be liable for any expense incurred in the preparation and submission of a bid. Where applicable a non-refundable fee for documents may be charged.

3.2 With certain exceptions, invitations to bid are only published in the Government Tender Bulletin. The Government Tender Bulletin may be obtained directly from the Government Printer, Private Bag X85, Pretoria 0001, or accessed electronically from www.treasury.gov.za

4. Standards

4.1 The goods supplied shall conform to the standards mentioned in the bidding documents and specifications.

5. Use of contract documents and information; inspection.

5.1 The supplier shall not, without the purchaser’s prior written consent, disclose the contract, or any provision thereof, or any specification, plan, drawing, pattern, sample, or information furnished by or on behalf of the purchaser in connection therewith, to any person other than a person employed by the supplier in the performance of the contract. Disclosure to any such employed person shall be made in confidence and shall extend only so far as may be necessary for purposes of such performance.

5.2 The supplier shall not, without the purchaser’s prior written consent, make use of any document or information mentioned in GCC clause 5.1 except for purposes of performing the contract.

5.3 Any document, other than the contract itself mentioned in GCC clause 5.1 shall remain the property of the purchaser and shall be returned (all copies) to the purchaser on completion of the supplier’s performance under the contract if so required by the purchaser.

5.4 The supplier shall permit the purchaser to inspect the supplier’s records relating to the performance of the supplier and to have them audited by auditors appointed by the purchaser, if so required by the purchaser.

6. Patent rights

6.1 The supplier shall indemnify the purchaser against all third-party claims of infringement of patent, trademark, or industrial design rights arising from use of the goods or any part thereof by the purchaser.

7. Performance security

- 7.1 Within thirty (30) days of receipt of the notification of contract award, the successful bidder shall furnish to the purchaser the performance security of the amount specified in SCC.
- 7.2 The proceeds of the performance security shall be payable to the purchaser as compensation for any loss resulting from the supplier's failure to complete his obligations under the contract.
- 7.3 The performance security shall be denominated in the currency of the contract, or in a freely convertible currency acceptable to the purchaser and shall be in one of the following forms:
 - (a) a bank guarantee or an irrevocable letter of credit issued by a reputable bank located in the purchaser's country or abroad, acceptable to the purchaser, in the form provided in the bidding documents or another form acceptable to the purchaser; or
 - (b) a cashier's or certified cheque
- 7.4 The performance security will be discharged by the purchaser and returned to the supplier not later than thirty (30) days following the date of completion of the supplier's performance obligations under the contract, including any warranty obligations, unless otherwise specified in SCC.

8. Inspections, tests and analyses

- 8.1 All pre-bidding testing will be for the account of the bidder.
- 8.2 If it is a bid condition that supplies to be produced or services to be rendered should at any stage during production or execution or on completion be subject to inspection, the premises of the bidder or contractor shall be open, at all reasonable hours, for inspection by a representative of the Department or an organization acting on behalf of the Department.
- 8.3 If there are no inspection requirements indicated in the bidding documents and no mention is made in the contract, but during the contract period it is decided that inspections shall be carried out, the purchaser shall itself make the necessary arrangements, including payment arrangements with the testing authority concerned.
- 8.4 If the inspections, tests and analyses referred to in clauses 8.2 and 8.3 show the supplies to be in accordance with the contract requirements, the cost of the inspections, tests and analyses shall be defrayed by the purchaser.
- 8.5 Where the supplies or services referred to in clauses 8.2 and 8.3 do not comply with the contract requirements, irrespective of whether such supplies or services are accepted or not, the cost in connection with these inspections, tests or analyses shall be defrayed by the supplier.
- 8.6 Supplies and services which are referred to in clauses 8.2 and 8.3 and which do not comply with the contract requirements may be rejected.
- 8.7 Any contract supplies may on or after delivery be inspected, tested or

analyzed and may be rejected if found not to comply with the requirements of the contract. Such rejected supplies shall be held at the cost and risk of the supplier who shall, when called upon, remove them immediately at his own cost and forthwith substitute them with supplies which do comply with the requirements of the contract. Failing such removal the rejected supplies shall be returned at the suppliers cost and risk. Should the supplier fail to provide the substitute supplies forthwith, the purchaser may, without giving the supplier further opportunity to substitute the rejected supplies, purchase such supplies as may be necessary at the expense of the supplier.

8.8 The provisions of clauses 8.4 to 8.7 shall not prejudice the right of the purchaser to cancel the contract on account of a breach of the conditions thereof, or to act in terms of Clause 23 of GCC.

9. Packing

9.1 The supplier shall provide such packing of the goods as is required to prevent their damage or deterioration during transit to their final destination, as indicated in the contract. The packing shall be sufficient to withstand, without limitation, rough handling during transit and exposure to extreme temperatures, salt and precipitation during transit, and open storage. Packing, case size and weights shall take into consideration, where appropriate, the remoteness of the goods' final destination and the absence of heavy handling facilities at all points in transit.

9.2 The packing, marking, and documentation within and outside the packages shall comply strictly with such special requirements as shall be expressly provided for in the contract, including additional requirements, if any, specified in SCC, and in any subsequent instructions ordered by the purchaser.

10. Delivery and documents

10.1 Delivery of the goods shall be made by the supplier in accordance with the terms specified in the contract. The details of shipping and/or other documents to be furnished by the supplier are specified in SCC.

10.2 Documents to be submitted by the supplier are specified in SCC.

11. Insurance

11.1 The goods supplied under the contract shall be fully insured in a freely convertible currency against loss or damage incidental to manufacture or acquisition, transportation, storage and delivery in the manner specified in the SCC.

12. Transportation

12.1 Should a price other than an all-inclusive delivered price be required, this shall be specified in the SCC.

13. Incidental services

13.1 The supplier may be required to provide any or all of the following services, including additional services, if any, specified in SCC:

- (a) performance or supervision of on-site assembly and/or commissioning of the supplied goods;
- (b) furnishing of tools required for assembly and/or maintenance of the supplied goods;
- (c) furnishing of a detailed operations and maintenance manual for each appropriate unit of the supplied goods;

- (d) performance or supervision or maintenance and/or repair of the supplied goods, for a period of time agreed by the parties, provided that this service shall not relieve the supplier of any warranty obligations under this contract; and
- (e) training of the purchaser's personnel, at the supplier's plant and/or on-site, in assembly, start-up, operation, maintenance, and/or repair of the supplied goods.

13.2 Prices charged by the supplier for incidental services, if not included in the contract price for the goods, shall be agreed upon in advance by the parties and shall not exceed the prevailing rates charged to other parties by the supplier for similar services.

14. Spare parts

14.1 As specified in SCC, the supplier may be required to provide any or all of the following materials, notifications, and information pertaining to spare parts manufactured or distributed by the supplier:

- (a) such spare parts as the purchaser may elect to purchase from the supplier, provided that this election shall not relieve the supplier of any warranty obligations under the contract; and
- (b) in the event of termination of production of the spare parts:
 - (i) Advance notification to the purchaser of the pending termination, in sufficient time to permit the purchaser to procure needed requirements; and
 - (ii) following such termination, furnishing at no cost to the purchaser, the blueprints, drawings, and specifications of the spare parts, if requested.

15. Warranty

15.1 The supplier warrants that the goods supplied under the contract are new, unused, of the most recent or current models, and that they incorporate all recent improvements in design and materials unless provided otherwise in the contract. The supplier further warrants that all goods supplied under this contract shall have no defect, arising from design, materials, or workmanship (except when the design and/or material is required by the purchaser's specifications) or from any act or omission of the supplier, that may develop under normal use of the supplied goods in the conditions prevailing in the country of final destination.

15.2 This warranty shall remain valid for twelve (12) months after the goods, or any portion thereof as the case may be, have been delivered to and accepted at the final destination indicated in the contract, or for eighteen (18) months after the date of shipment from the port or place of loading in the source country, whichever period concludes earlier, unless specified otherwise in SCC.

15.3 The purchaser shall promptly notify the supplier in writing of any claims arising under this warranty.

15.4 Upon receipt of such notice, the supplier shall, within the period specified in SCC and with all reasonable speed, repair or replace the defective goods or parts thereof, without costs to the purchaser.

15.5 If the supplier, having been notified, fails to remedy the defect(s) within the period specified in SCC, the purchaser may proceed to take

such remedial action as may be necessary, at the supplier's risk and expense and without prejudice to any other rights which the purchaser may have against the supplier under the contract.

- 16. Payment**
- 16.1 The method and conditions of payment to be made to the supplier under this contract shall be specified in SCC.
- 16.2 The supplier shall furnish the purchaser with an invoice accompanied by a copy of the delivery note and upon fulfillment of other obligations stipulated in the contract.
- 16.3 Payments shall be made promptly by the purchaser, but in no case later than thirty (30) days after submission of an invoice or claim by the supplier.
- 16.4 Payment will be made in Rand unless otherwise stipulated in SCC.
- 17. Prices**
- 17.1 Prices charged by the supplier for goods delivered and services performed under the contract shall not vary from the prices quoted by the supplier in his bid, with the exception of any price adjustments authorized in SCC or in the purchaser's request for bid validity extension, as the case may be.
- 18. Contract amendments**
- 18.1 No variation in or modification of the terms of the contract shall be made except by written amendment signed by the parties concerned.
- 19. Assignment**
- 19.1 The supplier shall not assign, in whole or in part, its obligations to perform under the contract, except with the purchaser's prior written consent.
- 20. Subcontracts**
- 20.1 The supplier shall notify the purchaser in writing of all subcontracts awarded under this contracts if not already specified in the bid. Such notification, in the original bid or later, shall not relieve the supplier from any liability or obligation under the contract.
- 21. Delays in the supplier's performance**
- 21.1 Delivery of the goods and performance of services shall be made by the supplier in accordance with the time schedule prescribed by the purchaser in the contract.
- 21.2 If at any time during performance of the contract, the supplier or its subcontractor(s) should encounter conditions impeding timely delivery of the goods and performance of services, the supplier shall promptly notify the purchaser in writing of the fact of the delay, its likely duration and its cause(s). As soon as practicable after receipt of the supplier's notice, the purchaser shall evaluate the situation and may at his discretion extend the supplier's time for performance, with or without the imposition of penalties, in which case the extension shall be ratified by the parties by amendment of contract.
- 21.3 No provision in a contract shall be deemed to prohibit the obtaining of supplies or services from a national department, provincial department, or a local authority.
- 21.4 The right is reserved to procure outside of the contract small quantities or to have minor essential services executed if an emergency arises, the

supplier's point of supply is not situated at or near the place where the supplies are required, or the supplier's services are not readily available.

21.5 Except as provided under GCC Clause 25, a delay by the supplier in the performance of its delivery obligations shall render the supplier liable to the imposition of penalties, pursuant to GCC Clause 22, unless an extension of time is agreed upon pursuant to GCC Clause 21.2 without the application of penalties.

21.6 Upon any delay beyond the delivery period in the case of a supplies contract, the purchaser shall, without canceling the contract, be entitled to purchase supplies of a similar quality and up to the same quantity in substitution of the goods not supplied in conformity with the contract and to return any goods delivered later at the supplier's expense and risk, or to cancel the contract and buy such goods as may be required to complete the contract and without prejudice to his other rights, be entitled to claim damages from the supplier.

22. Penalties

22.1 Subject to GCC Clause 25, if the supplier fails to deliver any or all of the goods or to perform the services within the period(s) specified in the contract, the purchaser shall, without prejudice to its other remedies under the contract, deduct from the contract price, as a penalty, a sum calculated on the delivered price of the delayed goods or unperformed services using the current prime interest rate calculated for each day of the delay until actual delivery or performance. The purchaser may also consider termination of the contract pursuant to GCC Clause 23.

23. Termination for default

23.1 The purchaser, without prejudice to any other remedy for breach of contract, by written notice of default sent to the supplier, may terminate this contract in whole or in part:

- (a) if the supplier fails to deliver any or all of the goods within the period(s) specified in the contract, or within any extension thereof granted by the purchaser pursuant to GCC Clause 21.2;
- (b) if the Supplier fails to perform any other obligation(s) under the contract; or
- (c) if the supplier, in the judgment of the purchaser, has engaged in corrupt or fraudulent practices in competing for or in executing the contract.

23.2 In the event the purchaser terminates the contract in whole or in part, the purchaser may procure, upon such terms and in such manner as it deems appropriate, goods, works or services similar to those undelivered, and the supplier shall be liable to the purchaser for any excess costs for such similar goods, works or services. However, the supplier shall continue performance of the contract to the extent not terminated.

23.3 Where the purchaser terminates the contract in whole or in part, the purchaser may decide to impose a restriction penalty on the supplier by prohibiting such supplier from doing business with the public sector for a period not exceeding 10 years.

23.4 If a purchaser intends imposing a restriction on a supplier or any

person associated with the supplier, the supplier will be allowed a time period of not more than fourteen (14) days to provide reasons why the envisaged restriction should not be imposed. Should the supplier fail to respond within the stipulated fourteen (14) days the purchaser may regard the intended penalty as not objected against and may impose it on the supplier.

23.5 Any restriction imposed on any person by the Accounting Officer / Authority will, at the discretion of the Accounting Officer / Authority, also be applicable to any other enterprise or any partner, manager, director or other person who wholly or partly exercises or exercised or may exercise control over the enterprise of the first-mentioned person, and with which enterprise or person the first-mentioned person, is or was in the opinion of the Accounting Officer / Authority actively associated.

23.6 If a restriction is imposed, the purchaser must, within five (5) working days of such imposition, furnish the National Treasury, with the following information:

- (i) the name and address of the supplier and / or person restricted by the purchaser;
- (ii) the date of commencement of the restriction
- (iii) the period of restriction; and
- (iv) the reasons for the restriction.

These details will be loaded in the National Treasury's central database of suppliers or persons prohibited from doing business with the public sector.

23.7 If a court of law convicts a person of an offence as contemplated in sections 12 or 13 of the Prevention and Combating of Corrupt Activities Act, No. 12 of 2004, the court may also rule that such person's name be endorsed on the Register for Tender Defaulters. When a person's name has been endorsed on the Register, the person will be prohibited from doing business with the public sector for a period not less than five years and not more than 10 years. The National Treasury is empowered to determine the period of restriction and each case will be dealt with on its own merits. According to section 32 of the Act the Register must be open to the public. The Register can be perused on the National Treasury website.

24. Anti-dumping and countervailing duties and rights

24.1 When, after the date of bid, provisional payments are required, or anti-dumping or countervailing duties are imposed, or the amount of a provisional payment or anti-dumping or countervailing right is increased in respect of any dumped or subsidized import, the State is not liable for any amount so required or imposed, or for the amount of any such increase. When, after the said date, such a provisional payment is no longer required or any such anti-dumping or countervailing right is abolished, or where the amount of such provisional payment or any such right is reduced, any such favourable difference shall on demand be paid forthwith by the contractor to the State or the State may deduct such amounts from moneys (if any) which may otherwise be due to the contractor in regard to supplies or services which he delivered or rendered, or is to deliver or render in terms of the contract or any other contract or any other amount which

may be due to him

25. Force Majeure

- 25.1 Notwithstanding the provisions of GCC Clauses 22 and 23, the supplier shall not be liable for forfeiture of its performance security, damages, or termination for default if and to the extent that his delay in performance or other failure to perform his obligations under the contract is the result of an event of force majeure.
- 25.2 If a force majeure situation arises, the supplier shall promptly notify the purchaser in writing of such condition and the cause thereof. Unless otherwise directed by the purchaser in writing, the supplier shall continue to perform its obligations under the contract as far as is reasonably practical, and shall seek all reasonable alternative means for performance not prevented by the force majeure event.

26. Termination for insolvency

- 26.1 The purchaser may at any time terminate the contract by giving written notice to the supplier if the supplier becomes bankrupt or otherwise insolvent. In this event, termination will be without compensation to the supplier, provided that such termination will not prejudice or affect any right of action or remedy which has accrued or will accrue thereafter to the purchaser.

27. Settlement of Disputes

- 27.1 If any dispute or difference of any kind whatsoever arises between the purchaser and the supplier in connection with or arising out of the contract, the parties shall make every effort to resolve amicably such dispute or difference by mutual consultation.
- 27.2 If, after thirty (30) days, the parties have failed to resolve their dispute or difference by such mutual consultation, then either the purchaser or the supplier may give notice to the other party of his intention to commence with mediation. No mediation in respect of this matter may be commenced unless such notice is given to the other party.
- 27.3 Should it not be possible to settle a dispute by means of mediation, it may be settled in a South African court of law.
- 27.4 Mediation proceedings shall be conducted in accordance with the rules of procedure specified in the SCC.
- 27.5 Notwithstanding any reference to mediation and/or court proceedings herein,
- (a) the parties shall continue to perform their respective obligations under the contract unless they otherwise agree; and
 - (b) the purchaser shall pay the supplier any monies due the supplier.

28. Limitation of liability

- 28.1 Except in cases of criminal negligence or willful misconduct, and in the case of infringement pursuant to Clause 6;
- (a) the supplier shall not be liable to the purchaser, whether in contract, tort, or otherwise, for any indirect or consequential loss or damage, loss of use, loss of production, or loss of profits or interest costs, provided that this exclusion shall not apply to any obligation of the supplier to pay penalties and/or damages to the purchaser; and

- (b) the aggregate liability of the supplier to the purchaser, whether under the contract, in tort or otherwise, shall not exceed the total contract price, provided that this limitation shall not apply to the cost of repairing or replacing defective equipment.
- 29. Governing language** 29.1 The contract shall be written in English. All correspondence and other documents pertaining to the contract that is exchanged by the parties shall also be written in English.
- 30. Applicable law** 30.1 The contract shall be interpreted in accordance with South African laws, unless otherwise specified in SCC.
- 31. Notices** 31.1 Every written acceptance of a bid shall be posted to the supplier concerned by registered or certified mail and any other notice to him shall be posted by ordinary mail to the address furnished in his bid or to the address notified later by him in writing and such posting shall be deemed to be proper service of such notice
- 31.2 The time mentioned in the contract documents for performing any act after such aforesaid notice has been given, shall be reckoned from the date of posting of such notice.
- 32. Taxes and duties** 32.1 A foreign supplier shall be entirely responsible for all taxes, stamp duties, license fees, and other such levies imposed outside the purchaser's country.
- 32.2 A local supplier shall be entirely responsible for all taxes, duties, license fees, etc., incurred until delivery of the contracted goods to the purchaser.
- 32.3 No contract shall be concluded with any bidder whose tax matters are not in order. Prior to the award of a bid the Department must be in possession of a tax clearance certificate, submitted by the bidder. This certificate must be an original issued by the South African Revenue Services.
- 33. National Industrial Participation Programme (NIP)** 33.1 The NIP Programme administered by the Department of Trade and Industry shall be applicable to all contracts that are subject to the NIP obligation.
- 34 Prohibition of Restrictive practices** 34.1 In terms of section 4 (1) (b) (iii) of the Competition Act No. 89 of 1998, as amended, an agreement between, or concerted practice by, firms, or a decision by an association of firms, is prohibited if it is between parties in a horizontal relationship and if a bidder (s) is / are or a contractor(s) was / were involved in collusive bidding (or bid rigging).
- 34.2 If a bidder(s) or contractor(s), based on reasonable grounds or evidence obtained by the purchaser, has / have engaged in the restrictive practice referred to above, the purchaser may refer the matter to the Competition Commission for investigation and possible imposition of administrative penalties as contemplated in the Competition Act No. 89 of 1998.

- 34.3 If a bidder(s) or contractor(s), has / have been found guilty by the Competition Commission of the restrictive practice referred to above, the purchaser may, in addition and without prejudice to any other remedy provided for, invalidate the bid(s) for such item(s) offered, and / or terminate the contract in whole or part, and / or restrict the bidder(s) or contractor(s) from conducting business with the public sector for a period not exceeding ten (10) years and / or claim damages from the bidder(s) or contractor(s) concerned.



Erf 4 Welmoed Estate

Typical Plot & Top Structure

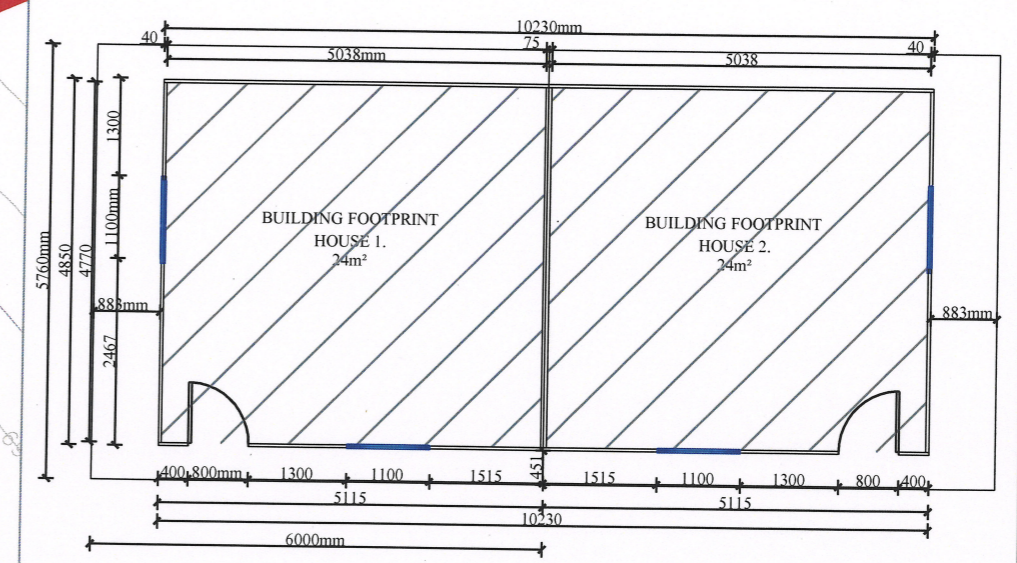





Scale 1:100

WELMOED ESTATE TRA ALTERNATIVE 1 (INDIVIDUAL PLOTS)

Notation:

292 Residential Plots

-  Plots
-  Refuse Depot
-  Toilets
-  Existing Cadastral Boundary

Note:

1. The width of the plots have been changed to 6m.
2. The new Eskom Servitude is to be used as a boundary, as a means to not deviate from the surveyor's approved base plan.

PROPOSED LAYOUT

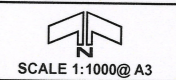

MARCH 2020

1A



Erf 4 Welmoed Estate

Proposed TRA

CO-ORDINATE TABLES

Point #	X	Y	Point #	X	Y	Point #	X	Y	Point #	X	Y	Point #	X	Y
1	3760636.8532	25889.4593	21	3760582.0081	25913.7917	41	3760601.2063	25883.0880	61	3760608.9311	25870.9089	81	3760571.3523	25874.9781
2	3760634.5173	25884.1942	22	3760579.6722	25908.5269	42	3760611.3628	25891.1850	62	3760606.5952	25865.6438	82	3760570.5395	25867.9416
3	3760629.0328	25886.6275	23	3760572.9711	25908.2176	43	3760609.0267	25885.9199	63	3760604.2593	25860.3787	83	3760568.2036	25862.6765
4	3760631.3686	25891.8926	24	3760570.6352	25902.9525	44	3760606.6909	25880.6548	64	3760603.4465	25873.3422	84	3760565.8677	25877.4114
5	3760625.8842	25894.3258	25	3760568.2993	25897.6874	45	3760616.8471	25888.7517	65	3760601.1106	25868.0771	85	3760565.0590	25890.3748
6	3760623.5483	25889.0607	26	3760578.4556	25905.7844	46	3760612.1753	25878.2215	66	3760598.7747	25862.8120	86	3760562.7191	25885.1097
7	3760618.0637	25891.4940	27	3760576.1197	25900.5193	47	3760623.3316	25886.3189	67	3760597.9620	25875.7754	87	3760560.3832	25879.8446
8	3760620.3996	25896.7591	28	3760573.7838	25895.2542	48	3760619.9957	25881.0534	68	3760595.6262	25870.5103	88	3760559.5702	25892.8080
9	3760614.9152	25899.1923	29	3760583.9401	25903.3511	49	3760617.6599	25875.7883	69	3760593.2903	25865.2452	89	3760557.2347	25887.5429
10	3760612.5793	25893.9272	30	3760581.6042	25898.0861	50	3760633.3007	25881.4520	70	3760592.4775	25878.2088	90	3760554.8988	25882.2778
11	3760607.0947	25896.3604	31	3760579.2683	25892.8210	51	3760628.6289	25870.9218	71	3760590.1416	25872.9435	91	3760554.0860	25895.2413
12	3760609.4306	25901.6255	32	3760589.4246	25900.9178	52	3760625.3845	25863.6092	72	3760587.8057	25867.6783	92	3760551.7501	25889.9762
13	3760603.9462	25904.0588	33	3760587.0887	25895.6528	53	3760623.0486	25858.3441	73	3760586.9930	25860.6419	93	3760549.4142	25884.7111
14	3760601.6103	25898.7937	34	3760584.7528	25890.3877	54	3760620.7127	25853.0790	74	3760584.6571	25875.3768	94	3760548.6015	25897.6745
15	3760598.4616	25906.4920	35	3760594.9091	25898.4847	55	3760619.9001	25866.0424	75	3760582.3212	25870.1117	95	3760546.2656	25892.4094
16	3760596.1257	25901.2269	36	3760590.2374	25887.9547	56	3760617.5842	25860.7734	76	3760581.5085	25863.0751	96	3760543.9207	25887.1443
17	3760592.9772	25908.9252	37	3760595.7219	25885.5212	57	3760615.2283	25855.5123	77	3760579.1726	25877.8100	97	3760543.1170	25900.1078
18	3760590.6412	25903.6602	38	3760600.3936	25896.0519	58	3760614.4155	25868.4757	78	3760576.8367	25872.5449	98	3760540.7811	25894.8427
19	3760585.1567	25906.0934	39	3760605.8781	25893.6162	59	3760612.0796	25863.2106	79	3760576.0240	25865.5083	99	3760538.4452	25889.5776
20	3760587.4928	25911.3585	40	3760603.5422	25888.3531	60	3760609.7437	25857.9455	80	3760573.6881	25860.2432	100	3760537.6326	25902.5410

WELMOED ESTATE TRA ALTERNATIVE 1 (INDIVIDUAL PLOTS)

Notation:

292 Residential Plots

Plots

Refuse Depot

Toilets

Existing Cadastral Boundary

CO-ORDINATES LAYOUT



SCALE 1:750 @ A2



MARCH 2020

1A

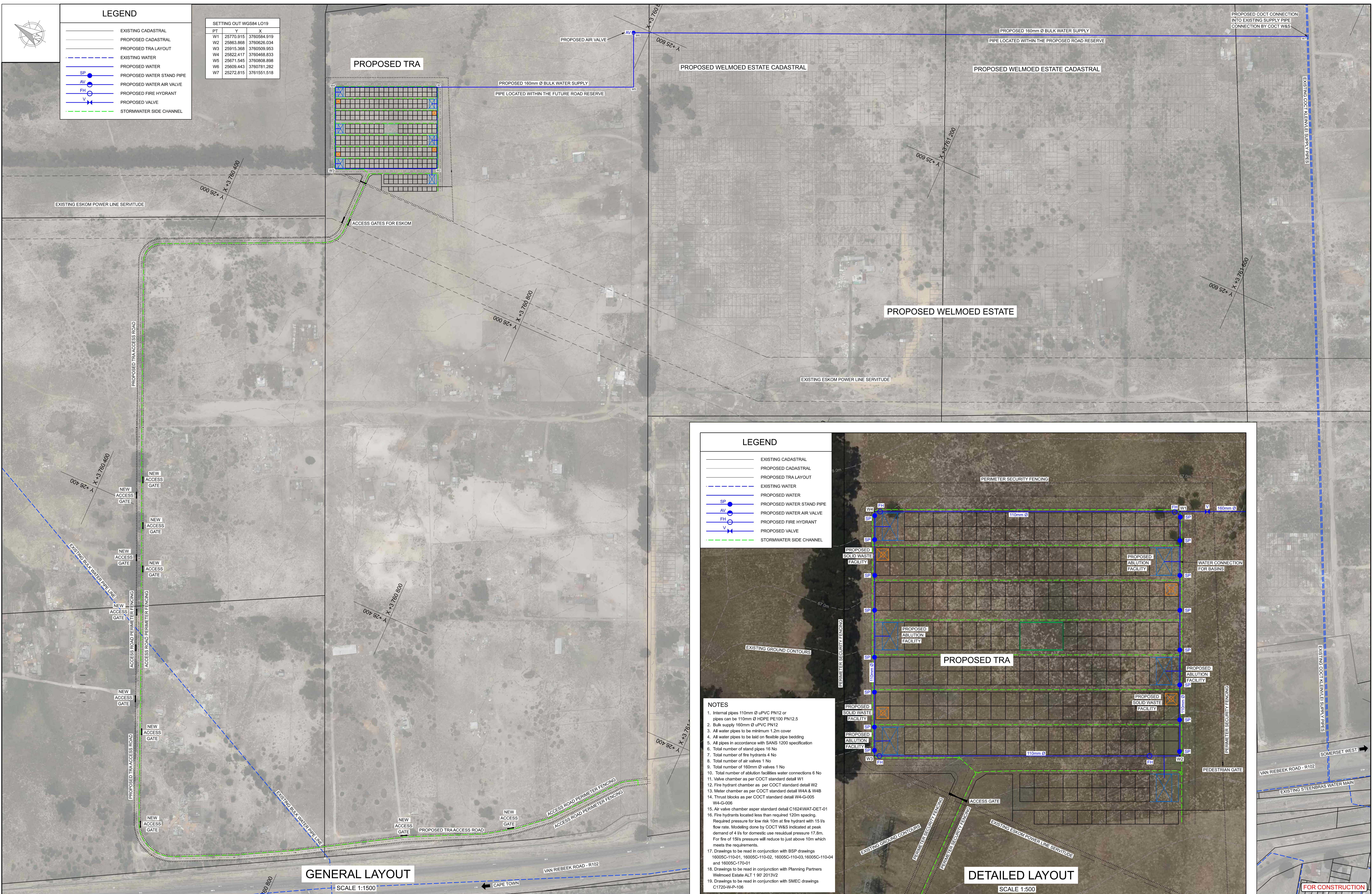

PT	Y	X
W1	25770.915	3765584.919
W2	25863.868	3769236.034
W3	25915.368	3769509.953
W4	25822.417	3760468.833
W5	25671.545	3760808.898
W6	25608.443	3760761.282
W7	25272.815	3761551.518

LEGEND	
	EXISTING CADASTRAL
	PROPOSED CADASTRAL
	PROPOSED TRA LAYOUT
	EXISTING WATER
	PROPOSED WATER
	PROPOSED WATER STAND PIPE
	PROPOSED WATER AIR VALVE
	PROPOSED FIRE HYDRANT
	PROPOSED VALVE
	STORMWATER SIDE CHANNEL

- NOTES**
- Internal pipes 110mm Ø uPVC PN12 or pipes can be 110mm Ø HDPE PE100 PN12.5
 - Bulk supply 160mm Ø uPVC PN12
 - All water pipes to be minimum 1.2m cover
 - All water pipes to be laid on flexible pipe bedding
 - All pipes in accordance with SANS 1200 specification
 - Total number of stand pipes 16 No
 - Total number of fire hydrants 4 No
 - Total number of air valves 1 No
 - Total number of 160mm Ø valves 1 No
 - Total number of ablation facilities water connections 6 No
 - Valve chamber as per COCT standard detail W1
 - Fire hydrant chamber as per COCT standard detail W2
 - Meter chamber as per COCT standard detail W4A & W4B
 - Thrust blocks as per COCT standard detail W4-G-005 W4-G-006
 - Air valve chamber as per standard detail C1624/WAT-DET-01
 - Fire hydrants located less than required 120m spacing. Required pressure for low risk 10m at fire hydrant with 15 l/s flow rate. Modelling done by COCT W&S indicated at peak demand of 4 l/s for domestic use residual pressure 17.8m. For fire of 150s pressure will reduce to just above 10m which meets the requirements.
 - Drawings to be read in conjunction with BSP drawings 16005C-110-01, 16005C-110-02, 16005C-110-03, 16005C-110-04 and 16005C-110-01
 - Drawings to be read in conjunction with Planning Partners Welmoed Estate ALT 1 90'2013V2
 - Drawings to be read in conjunction with SMEC drawings C1720-W-P-106

Revision	Date	Description

Engineer
BSP
 CONSULTING ENGINEERS
 Pr. Eng: Name: _____ Signature: _____
 Pr. No: _____

Engineer
SMEC
 South Africa
 Member of the Surbana Jurong Group
 Pr. Eng: Name: _____ Signature: _____
 Pr. No: _____

Client
Western Cape Government
 Human Settlements
 Pr. Eng: Name: _____ Signature: _____
 Pr. No: _____

	NAME	SIGNATURES
Designed	M. KOEKEMOER	
Drawn	M. KOEKEMOER	
Checked	H.MKHIZE	

Project	
WELMOED ESTATE DEVELOPMENT	
PROPOSED TRA SERVICES LAYOUT	

Contract No.	C1720	20-11-2019
Drawing No.	C1720-W-P-107	
SCALE	AS SHOWN	
REV.	-	
ORIGINAL PAPER SIZE	A0	

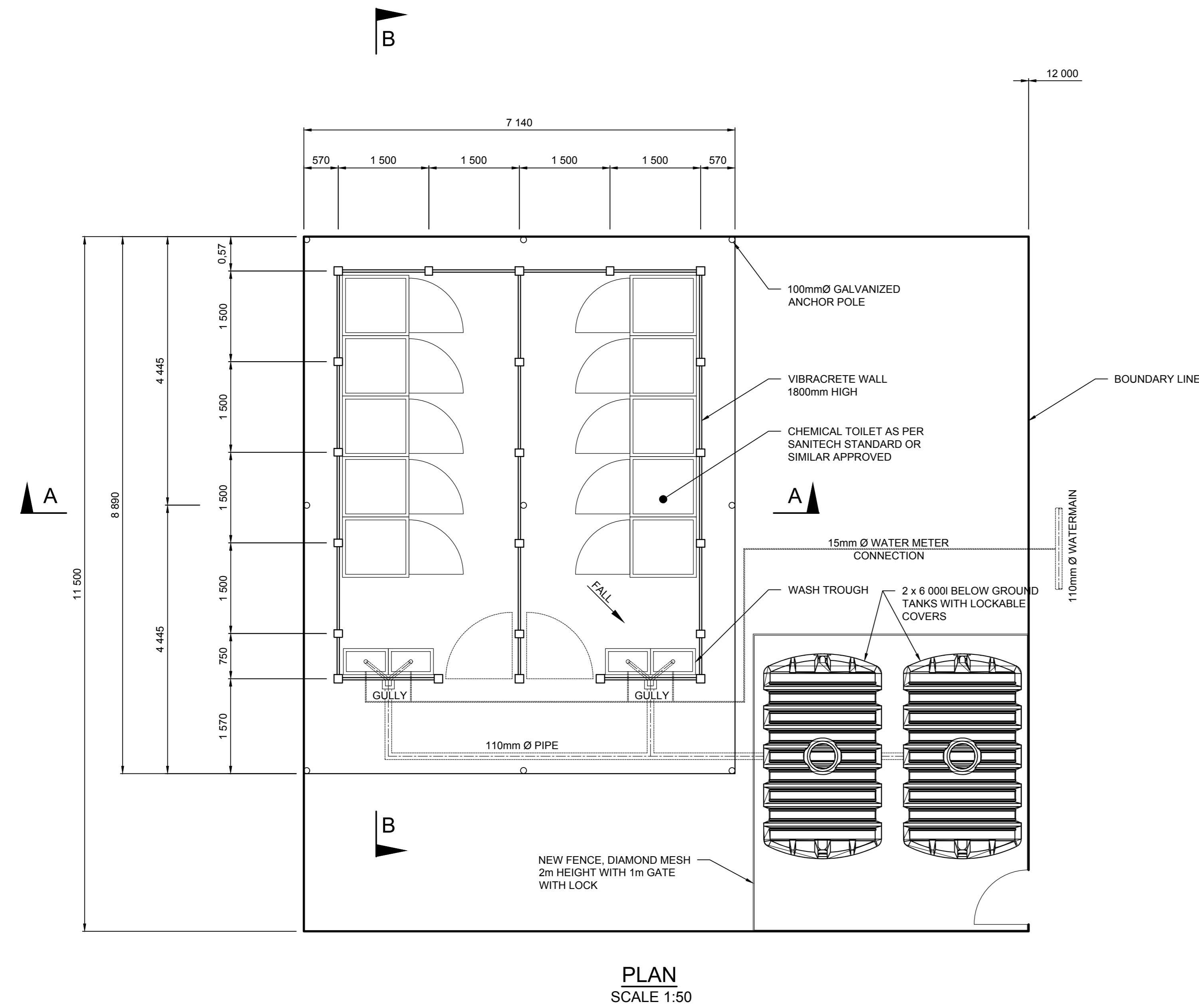

PLAN
SCALE 1:50

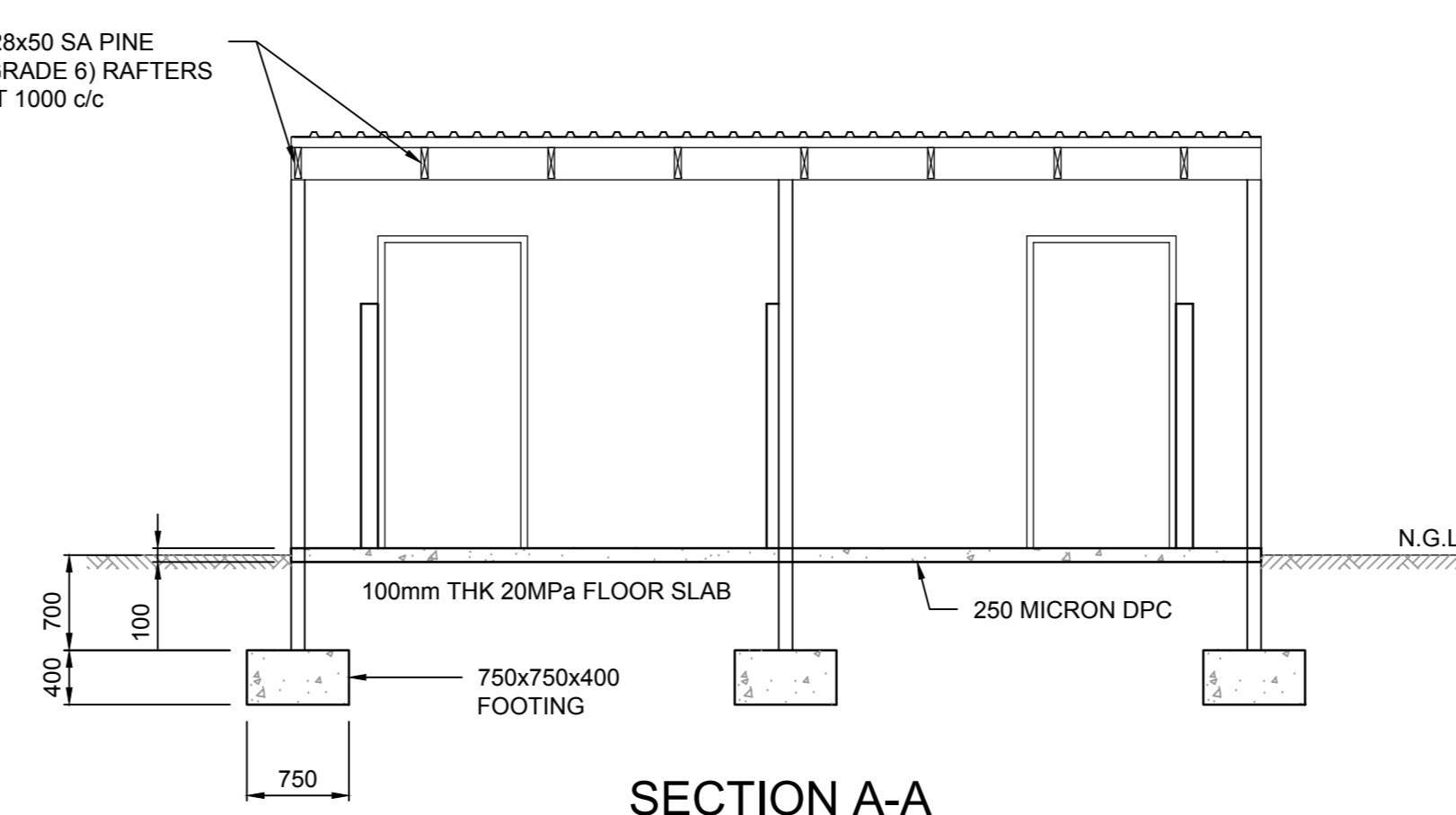

SECTION A-A
SCALE 1:50

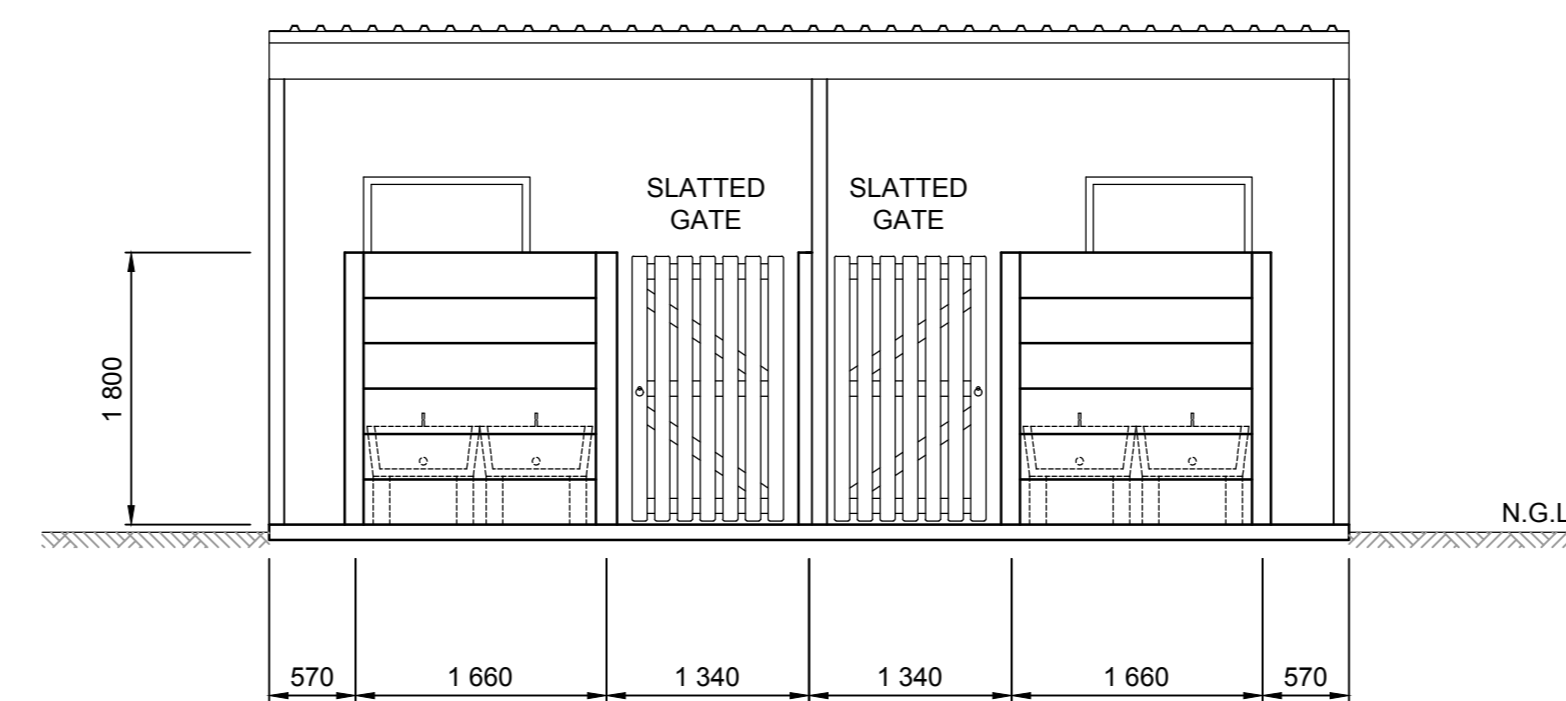

FRONT ELEVATION
SCALE 1:50

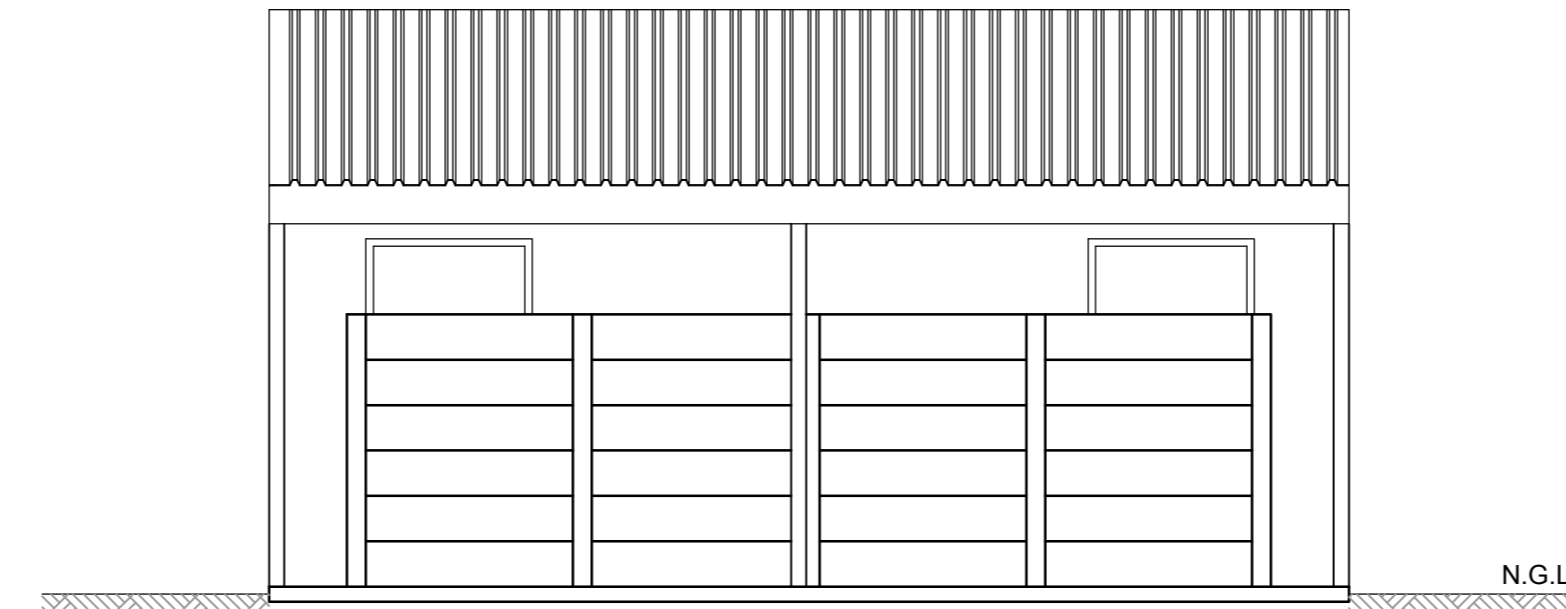

BACK ELEVATION
SCALE 1:50

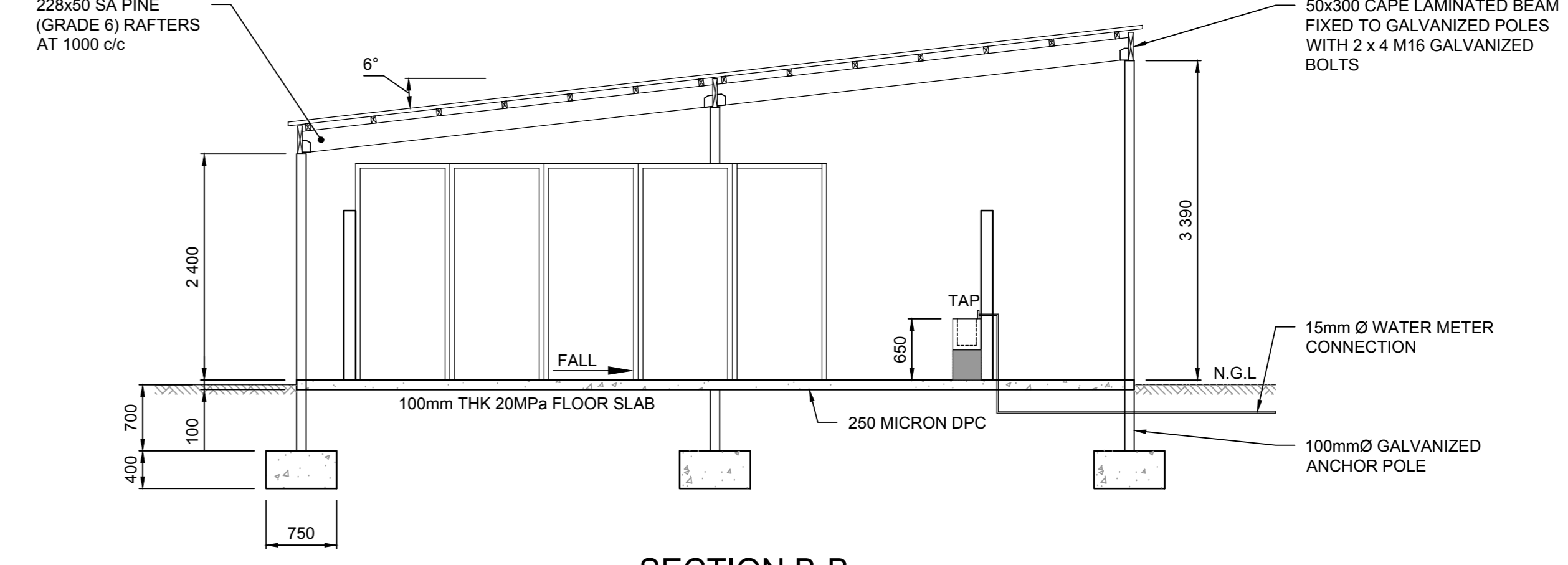

SECTION B-B
SCALE 1:50

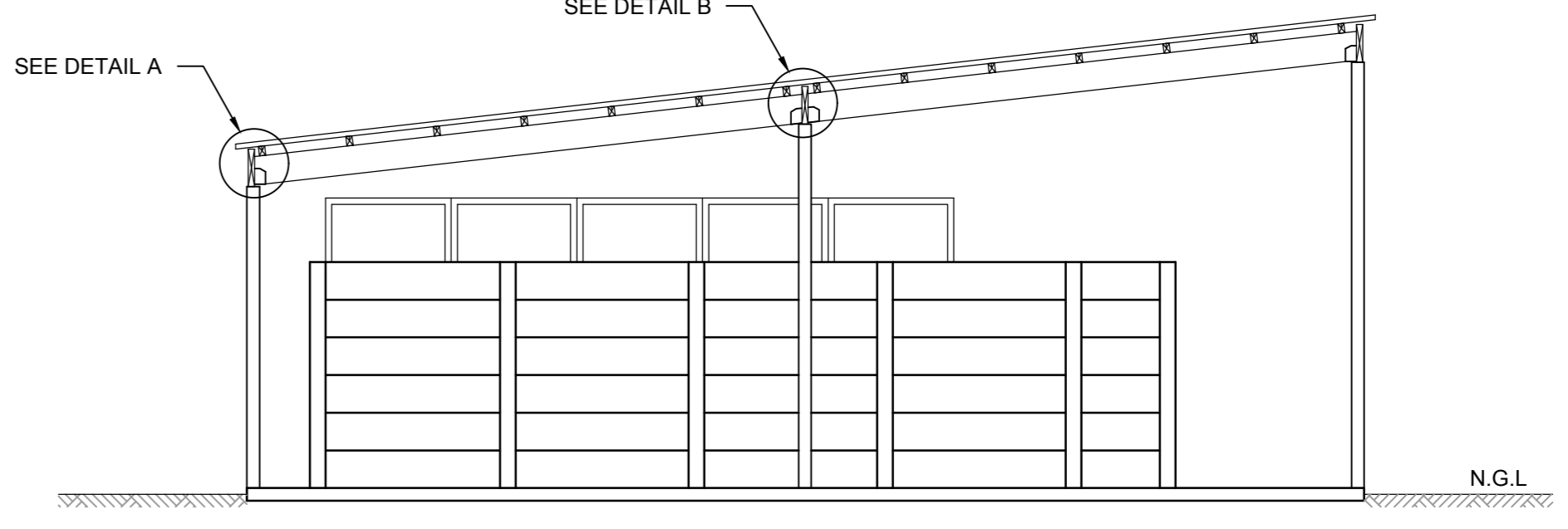

SIDE ELEVATION
SCALE 1:50

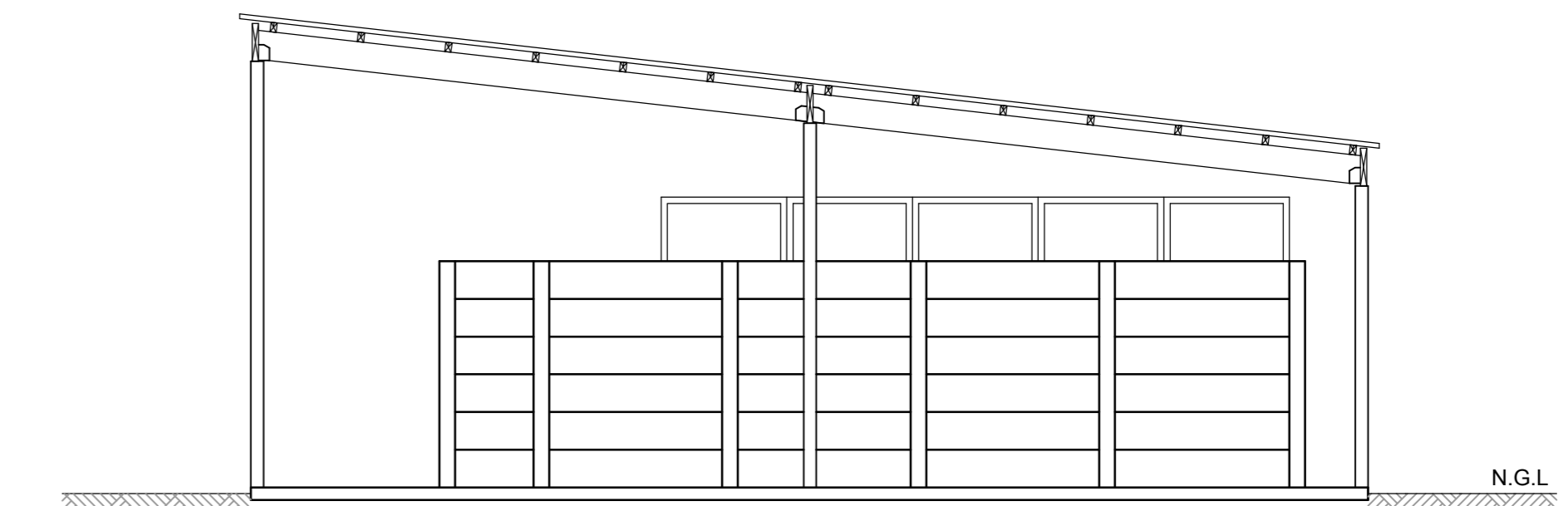

SIDE ELEVATION
SCALE 1:50

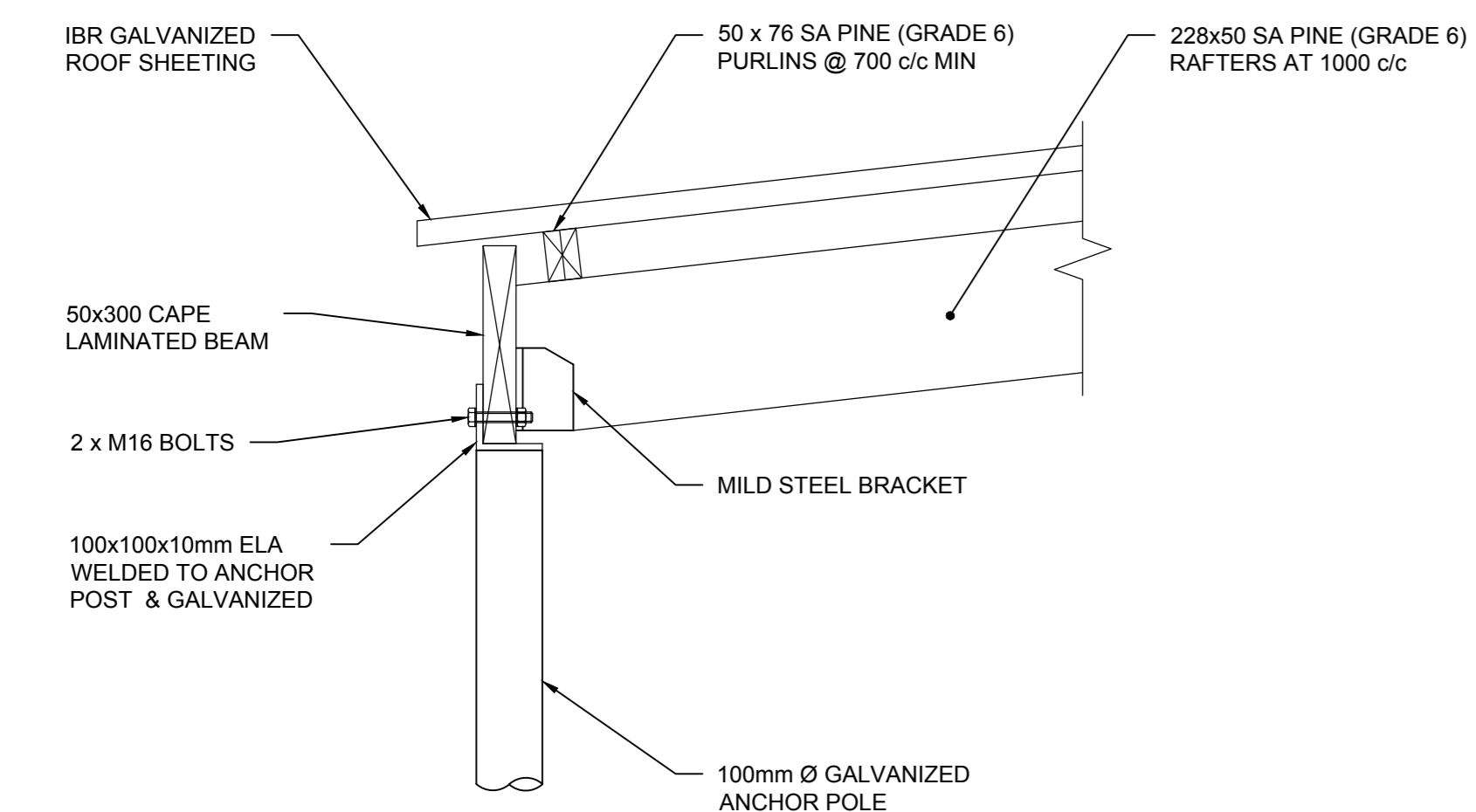

DETAIL A
SCALE 1:10

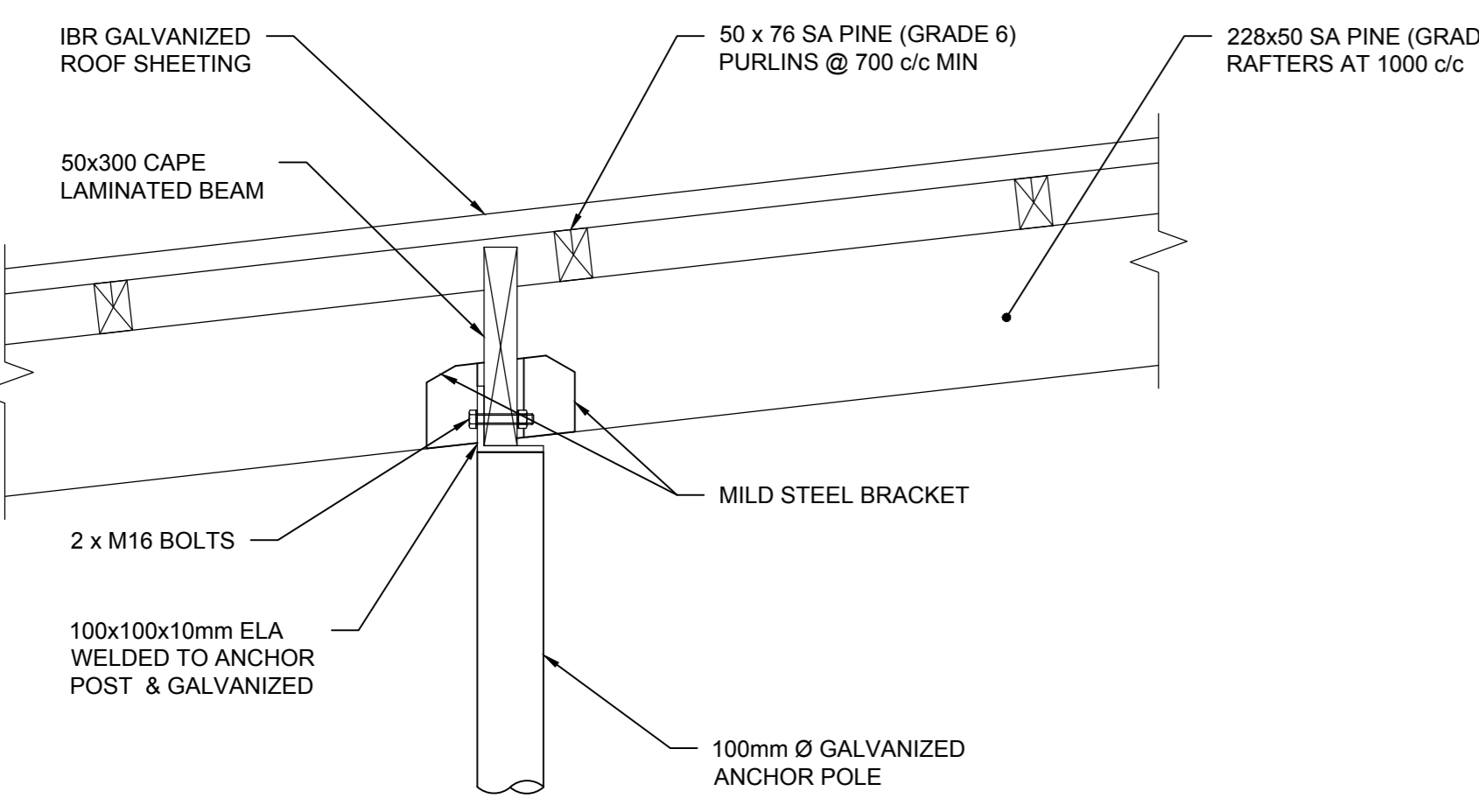

DETAIL B
SCALE 1:10

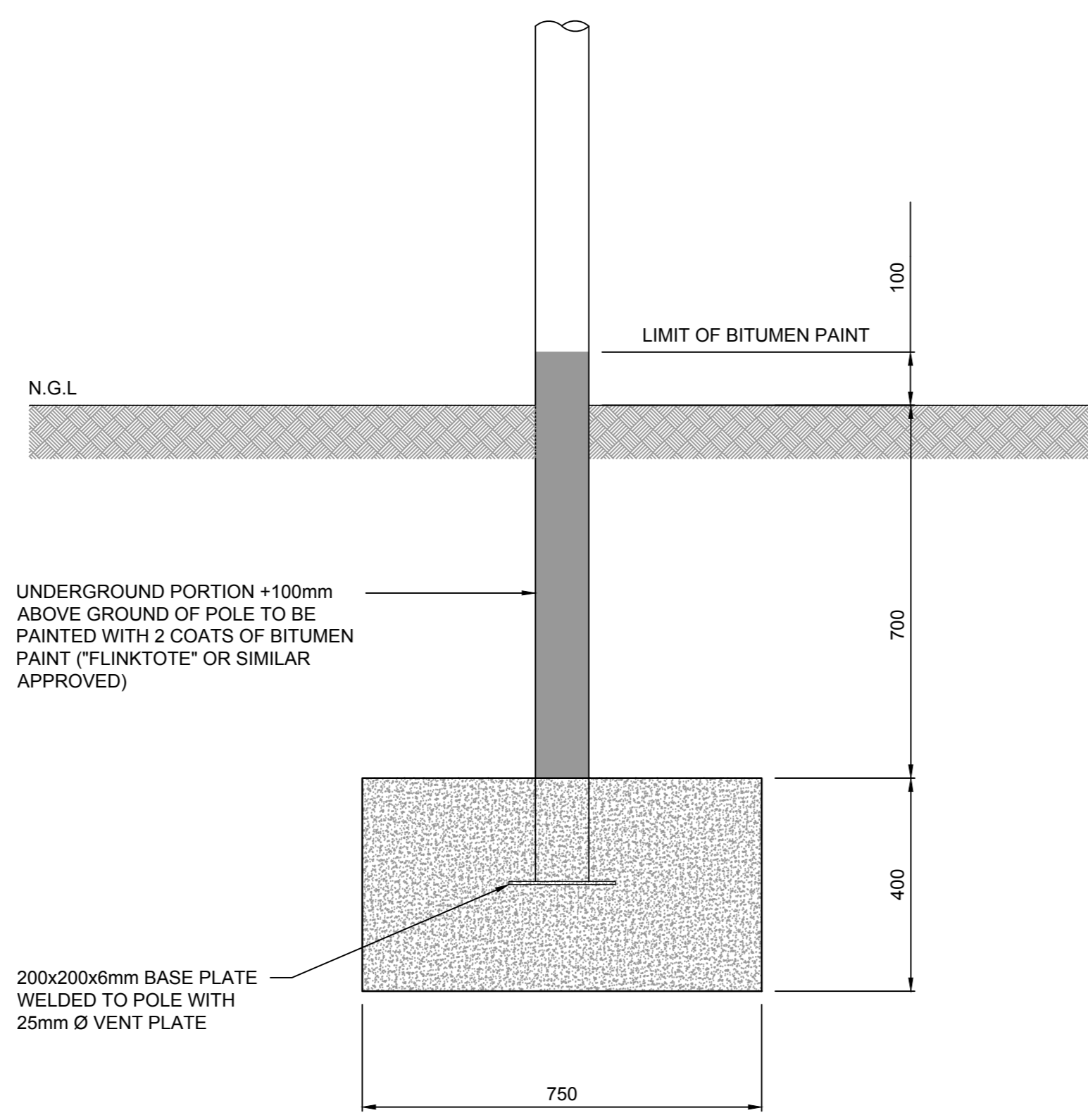

SECTION THROUGH POLE AND FOOTING
SCALE 1:10

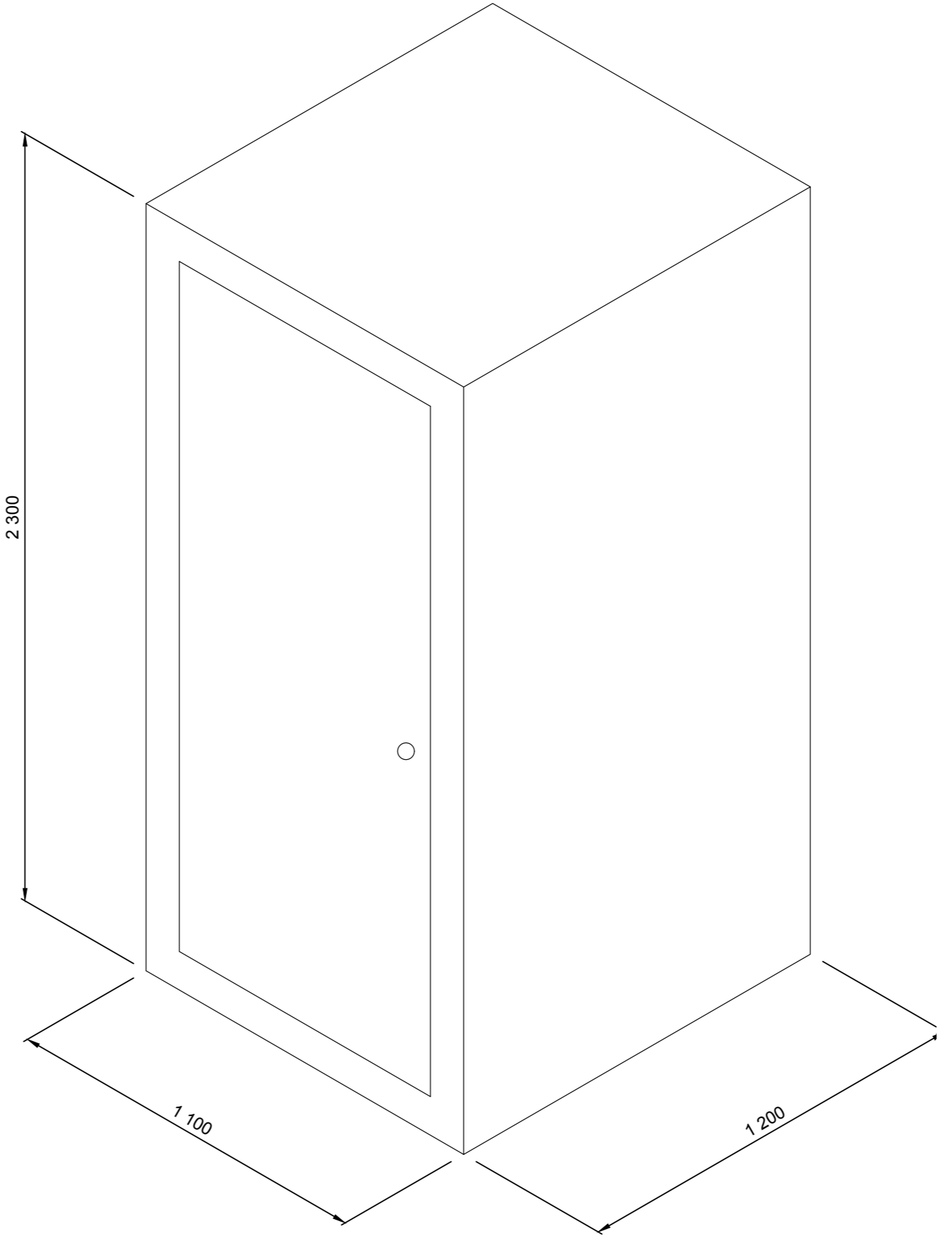

TYPICAL CHEMICAL TOILET
SCALE 1:15

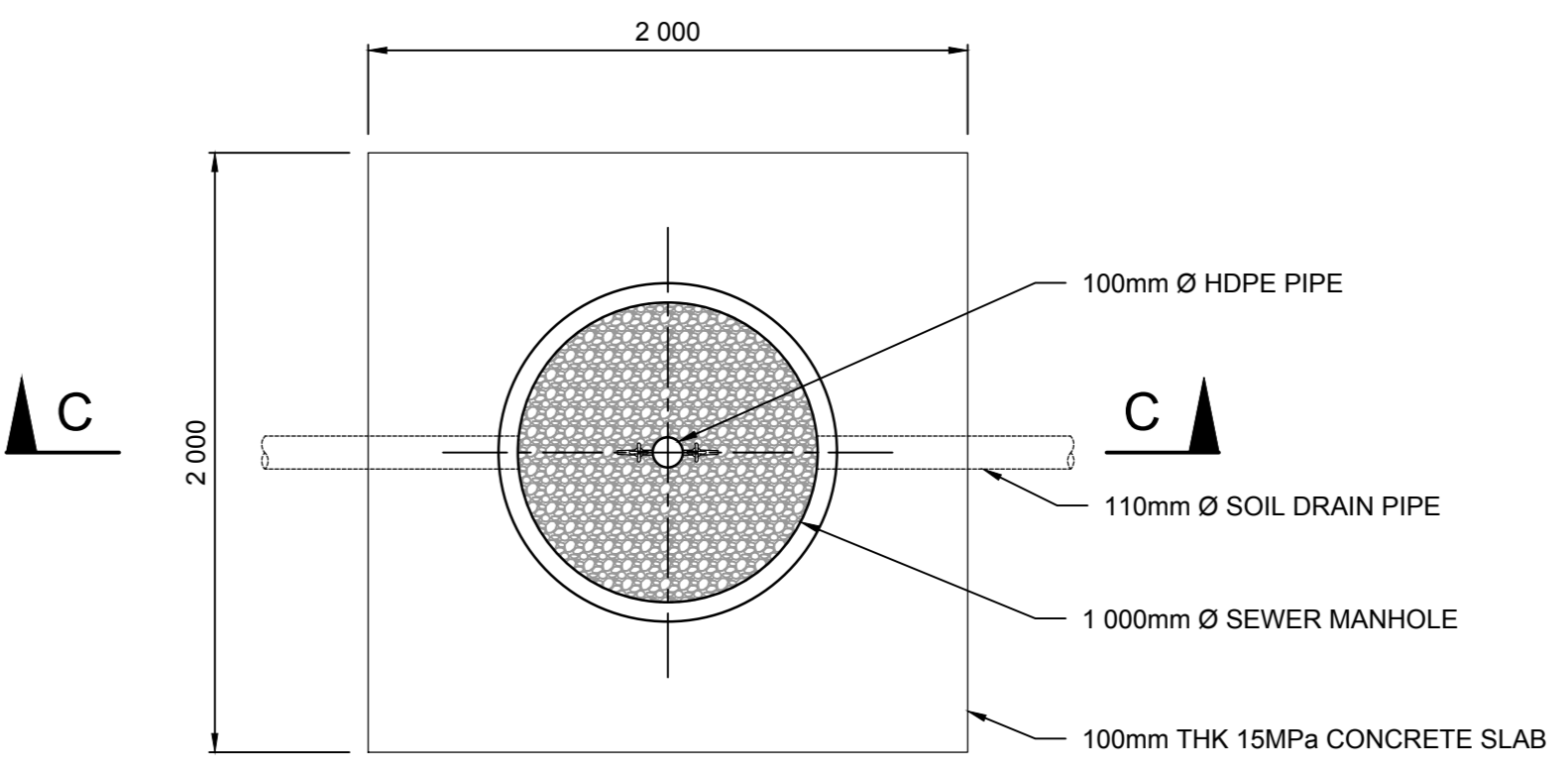

STAND PIPE DETAIL
SCALE 1:25

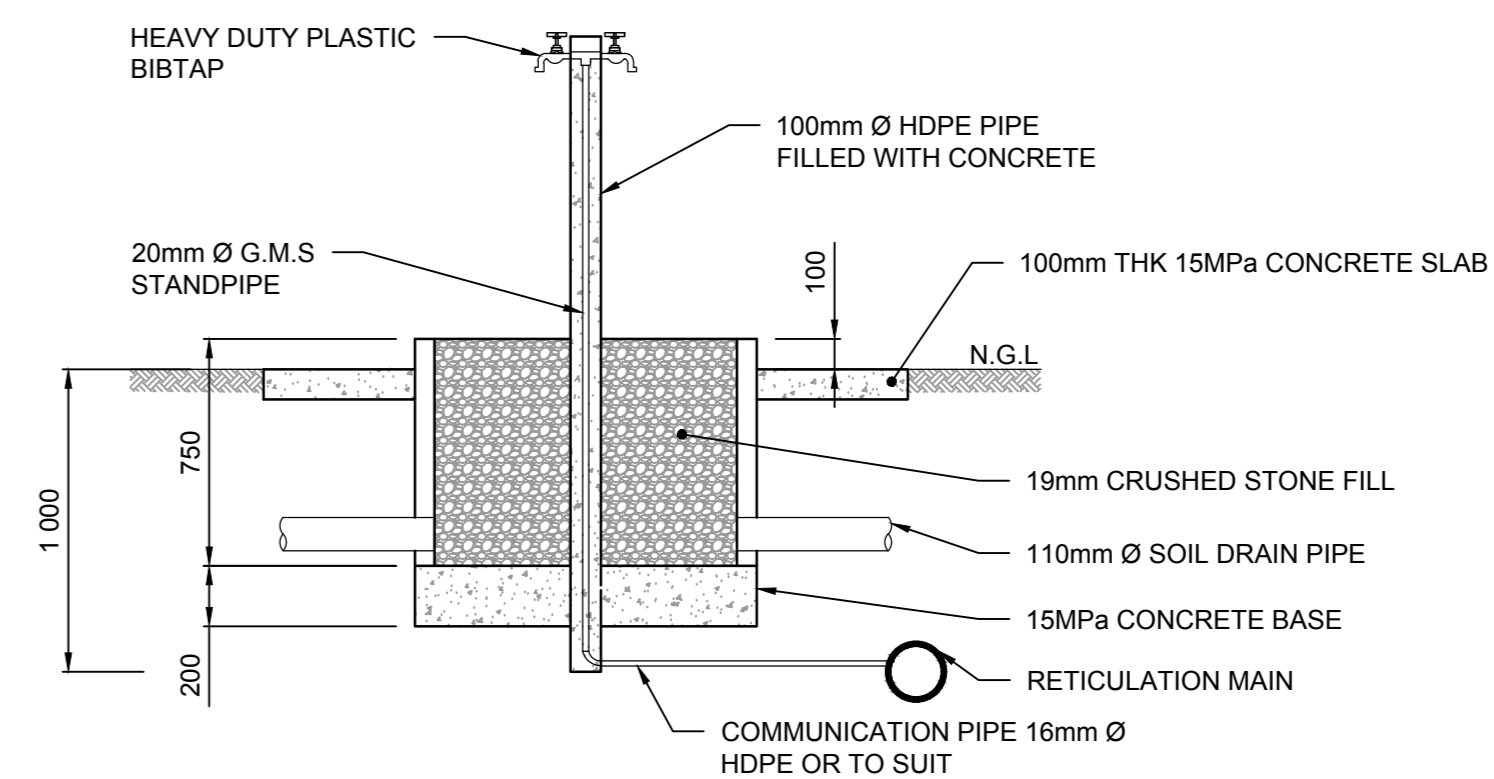

SECTION C-C
SCALE 1:25

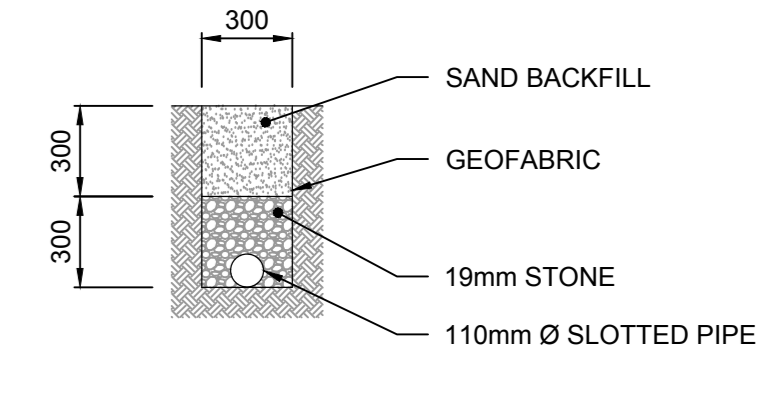

SUBSOIL DRAIN
SCALE 1:25

- NOTE:**
- COLUMN FOOTINGS:
 - DESIGN SOLUTION TO BE STRICTLY IN ACCORDANCE WITH THE PROVISION OF THE SA/CS/STRUCTURE CODE OF PRACTICE. THE FOLLOWING DESIGN TO BE ACCORDANCE WITH NHBCR HOME BUILDING MANUAL FOR THE SOIL CONDITIONS CLASSIFIED AS C, H, R OR S.
 - MIN 750 X 750 X 400mm AND 10 MPa CONCRETE.
 - TOP OF FOOTING SHOULD BE MIN 500mm BELOW NGL.
 - FLOOR SLAB:
 - BACKFILL TO BE WETTED AND COMPACTED (100MM BY HAND 150MM BY MACHINE)
 - FLOOR SLABS SHOULD BE A MIN OF 100MM THICK AND OF 20 MPa CONCRETE.
 - A DPC MEMBRANE OF 250 MICRON MUST BE LAID ON A 50mm SANDBED UNDER THE SLAB OR RAFT WITH 200mm OVERLAPS AND ALL JOINTS SEALED.
 - SURFACE BEDS TO BE WETTED AND COMPACTED IN LAYERS NOT EXCEEDING 150mm.
 - EXTERNAL AND DRAINAGE:
 - VIBRACRETE WALLS AS PER MANUFACTURER'S SPECIFICATIONS.
 - PLUMBING AND DRAINAGE:
 - WATER PIPE TOP BE 15mm POLYCOB LAID AT A MINIMUM DEPTH OF 450mm WITH SINGLE STOPCOCK.
 - 110mm Ø DRAIN PIPE TO BELOW GROUND TANKS, FROM WHB HAND BASIN GULLY.
 - TAPS TO BE 15mm Ø HEAVY DUTY PLASTIC
 - ROOF STRUCTURE:
 - 228 X 50 SA PINE RAFTERS @ 1000 MAX. BOLTED TO 50 X 300 CAPE LAMINATED BEAMS. IFR GALVANIZED ROOF SHEETS FIXED ON 50 X 76 SA PINE PURLINS.
 - GALVANIZED METAL ROOF SHEETS MUST COMPLY WITH SABS S34 AND BE OF CLASS Z600 GALVANIZING.
 - GENERAL:
 - WOODEN GATES OR SIMILAR MUST BE OILED OR VARNISHED BEFORE INSTALLATION (2 COATS). ALL CONSTRUCTION METHODS AND WORKMANSHIP TO COMPLY WITH THE RELEVANT SABS CODES OF PRACTICE AND NHBCR TECHNICAL REQUIREMENTS.

FOR CONSTRUCTION

Revision	Date	Description

Engineer

 75 Van der Stel, Oudkale, Beaufortia 7535
 P O Box 406 Parow 7500
 Tel: +27 21 919 5904
 Fax: +27 21 919 5908
 Email: bsp@bsp.co.za

Engineer

 Member of the Surbana Jurong Group
 65 Riebeeck Street, Cape Town 8001, South Africa
 PO Box 8022, T +27 21 417 2900, Roggebaai 8012, F +27 21 417 2999, South Africa, www.smecc.com

Client

 Human Settlements

NAME	SIGNATURES
Designed M. KOEKEMOER	
Drawn Y. ISAACS	
Checked M. KOEKEMOER	

Project	Contract No.	Drawing No.	SCALE	REV.	ORIGINAL PAPER SIZE
WELMOED ESTATE DEVELOPMENT		C1720-W-P-106	AS SHOWN	00	A0
Plan Description					
TRA ABLUTION BLOCK					

Project	Contract No.	Drawing No.	SCALE	REV.	ORIGINAL PAPER SIZE
WELMOED ESTATE DEVELOPMENT		C1720-W-P-106	AS SHOWN	00	A0
Plan Description					
TRA ABLUTION BLOCK					